



# QUALITY BUILT IN

Aerospace demands for ultra-high performance materials led to the development of the C-type 18% nickel maraging tool steels. The strongest of this type of material is C-350 with a nominal ultimate tensile strength of 350 ksi or 350,000 pounds per square inch. This material has higher strength and better wear properties than any material we have tested. ALL gears in Jiffy Air Tool attachments are made from this superior material.



You will find the same devotion to quality in all of our parts, housings made from A2, cover plates made from 1095 spring steel, bearing shafts made from E52100, and drive shafts made from chrome-moly tool steel. The limited space available for airframe assembly demands strong small tools. Superior materials combined with three generations of experience building tools for aerospace is represented in the modular installation system in this catalog.

From design to manufacturing the people at Jiffy Air Tool always strive to deliver the best tools possible.





17169  
90 Degree Attachment\*  
Page 7

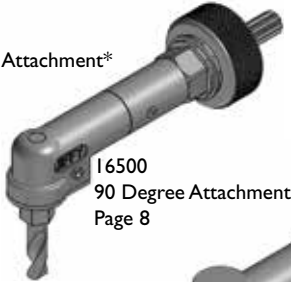

16500  
90 Degree Attachment  
Page 8

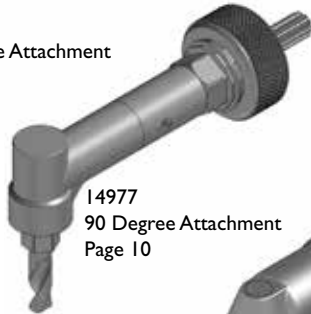

14977  
90 Degree Attachment  
Page 10

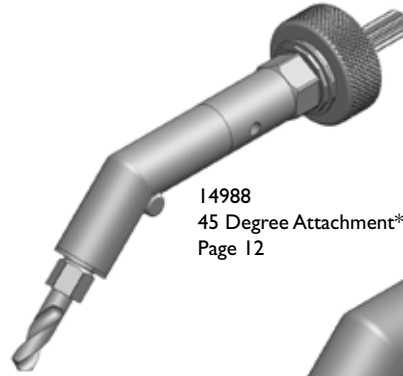

14988  
45 Degree Attachment\*  
Page 12

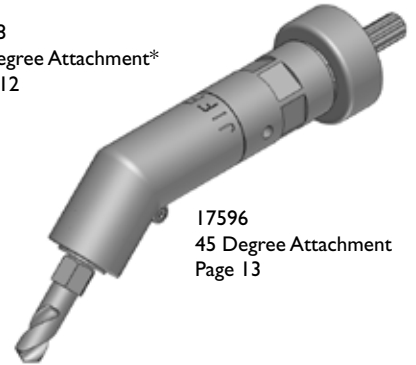

17596  
45 Degree Attachment  
Page 13

Pancake Attachments  
Series 1 Page 16  
Series 2 Page 18

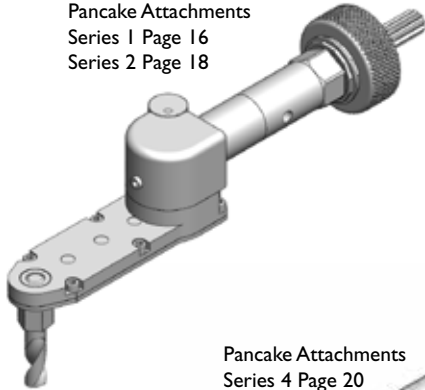

18107  
90 Degree Attachment  
Page 11  
*Vinyl Cover Available*

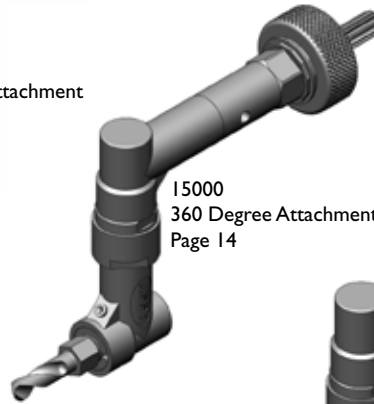

15000  
360 Degree Attachment  
Page 14

Pancake Attachments  
Series 4 Page 20

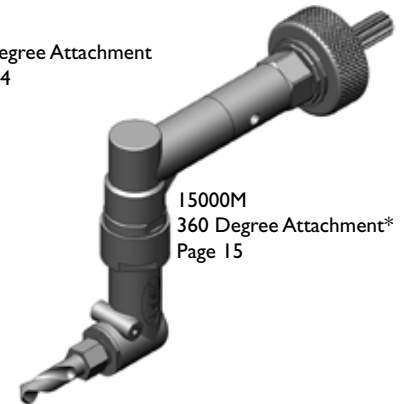
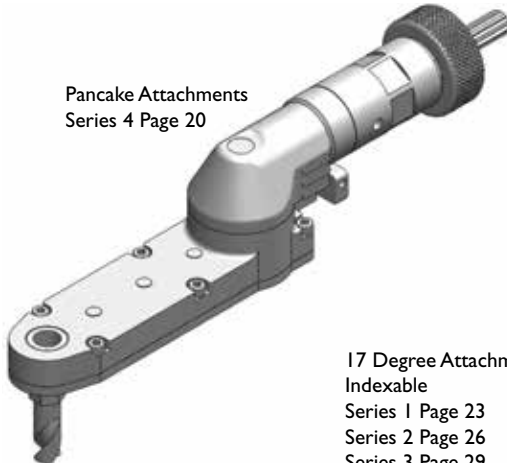

15000M  
360 Degree Attachment\*  
Page 15

17 Degree Attachments  
Indexable  
Series 1 Page 23  
Series 2 Page 26  
Series 3 Page 29

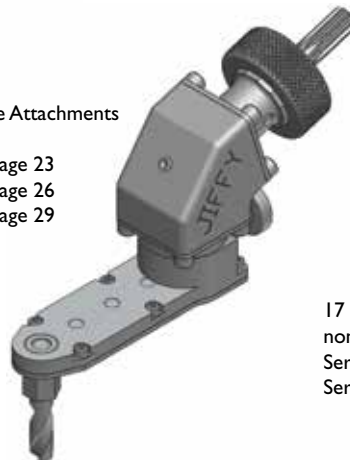

Chuck Attachments  
Page 34

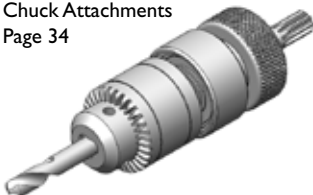

17 Degree Attachments  
non-indexing  
Series 3 Page 32  
Series 4 Page 33

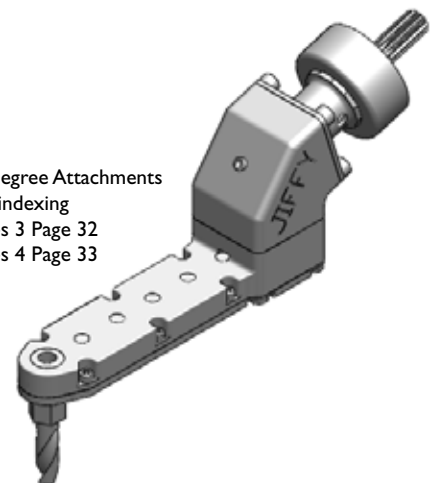

\* Indicates that the output gear rides in a bushing instead of ball bearings.  
Speed should be limited to 3000 RPM or less.

1.5 HP Offset Motors  
Page 37



.85 HP Motors Page 41  
.85 HP reverse running Page 42



.30 HP Motors Page 45  
.30 HP reverse running Page 46



.90 HP Reversible  
Offset Motors  
Page 39



.40 HP Reversible Motors  
Page 49



1.5 HP Straight Motors  
Page 38

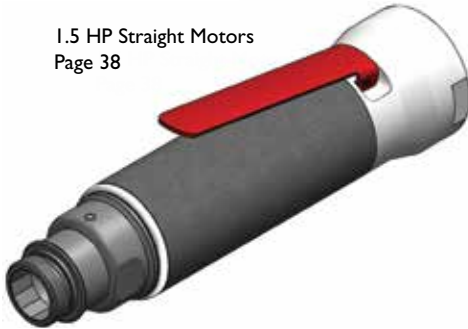

.85 HP Straight Motors Page 43  
.85 HP reverse running Page 44



.30 HP Straight Motors Page 47  
.30 HP reverse running Page 48



.90 HP Reversible  
Straight Motors  
Page 40



.40 HP Reversible  
Straight Motors  
Page 50

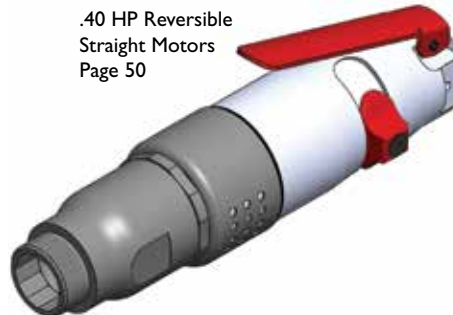

Safety Levers  
For Straight Motors  
Page 51



PHONE: 775 883 1072 FAX: 775 883 4857



*Vinyl Cover Available  
for Series 1, 2, and 3 L Types*

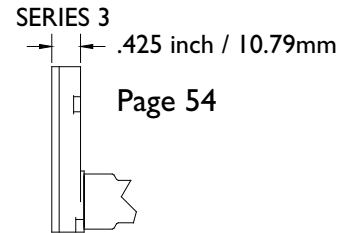
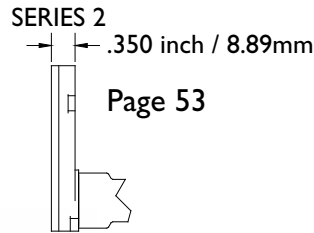
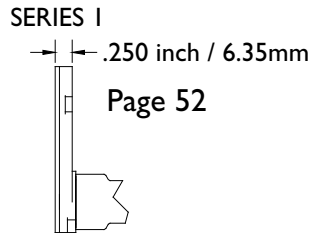

**Series 4**

A larger more robust series  
for 3/8-24 threaded drills

Page 55

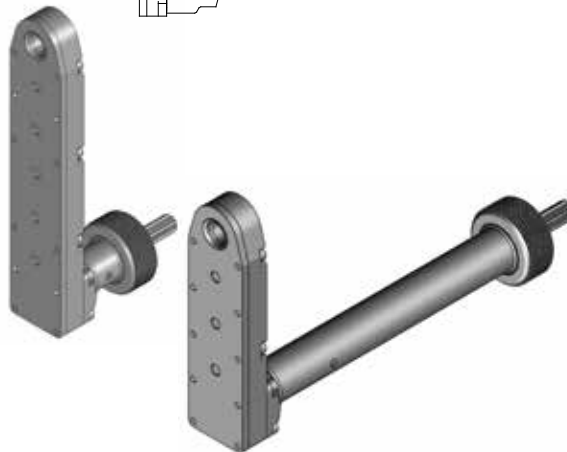

**Thinline**

With a .210 drill center to edge  
distance and a .560 width the Thinline  
Drill Attachments can reach areas not  
possible with our standard attachments.

Page 56



**Flat Angle Drills**

Series 1 Page 57

Series 2 Page 58

Series 3 Page 59



*Vinyl Cover Available  
for Series 1, 2, and 3 L Types*

1.5 HP Motors  
with Chucks  
Page 60

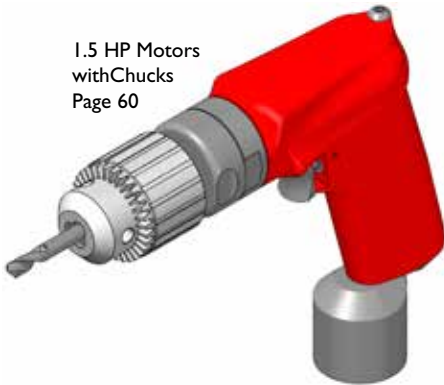

.90 HP Reversible Motors  
with Chucks  
Page 61



.85 HP Motors  
with Chucks  
Page 62



Torque Reaction  
Safety Handles  
Page 64



.30 HP Motors  
with Chucks  
Page 63

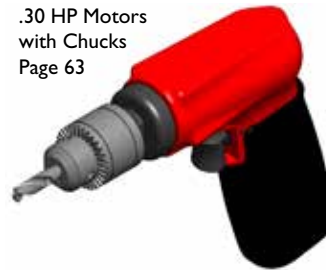

### Replacement Drill Attachments

90 Degree Attachments  
Page 65

*Vinyl Cover  
Available*



45 Degree Attachments  
Page 66



360 Degree Attachments  
Page 66

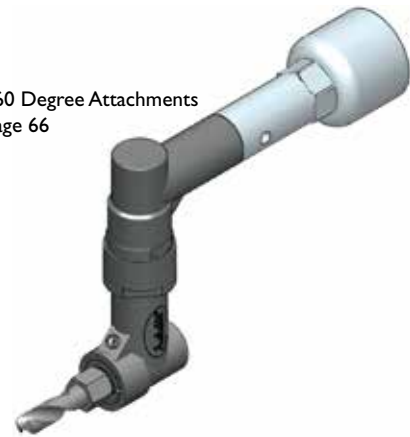

Series 1 Pancake Attachments  
Page 67

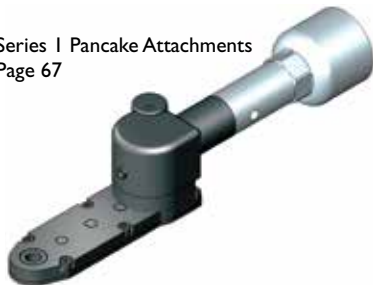

Series 2 Pancake Attachments  
Page 68

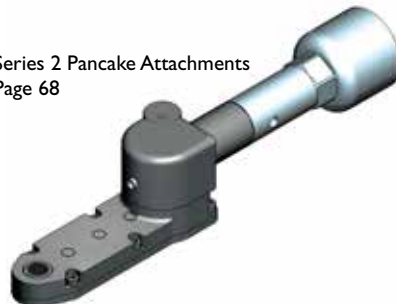

Series 4 Pancake Attachments  
Page 69

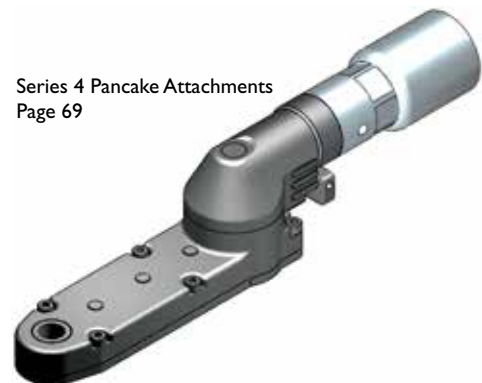

Adapt to drills made by  
Dotco  
Desoutter  
Rockwell  
American Pneumatic  
Buckeye

PHONE: 775 883 1072 FAX: 775 883 4857

# Build a custom drill kit to fit your needs



## Drastically reduce your number of air motors

- The Jiffy Modular Drill system offers complete flexibility with a wide variety of drill attachments.
- Create a custom drill kit to fit your application.
- Our high impact co-polymer cases feature form fit foam interiors to organize all motor and drill attachments.
- Permanently attached metal nameplates listing kit numbers and all components.
- A USB drive with all part breakdowns.

***Lubrication Instructions***

***Recommended Drill RPM's per drill size chart***

***Fraction-Decimal-millimeter conversion chart***

***Service Policy***

***Page 70***

***Page 71***

***Page 72***

***Inside Back Cover***

	A	B	C	D	90 DEGREE DRILL	
INCH	.312	.937	.625	3.550	MAXIMUM RECOMMENDED DRILL DIAMETER	.250
MM	7.92	23.8	15.87	90.17		6.35 mm



CLOSE CENTER TO EDGE 90 DEGREE DRILL ATTACHMENT

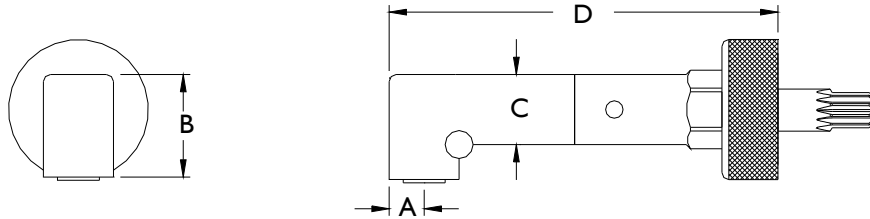

17169 ATTACHMENT ONLY  
PART OF THE JIFFY MODULAR DRILL SYSTEM

The output gear rides in a bushing instead of ball bearings.  
Attachment speed should be limited to 3000 RPM or less.



Shown with  
17639  
.85 HP 3000 RPM  
Straight Motor

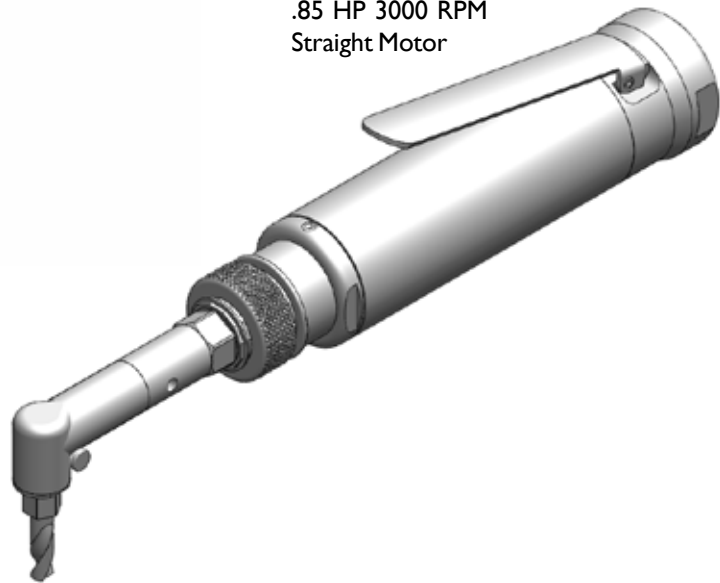

You must select an internal thread

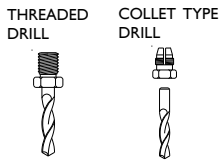

INTERNAL THREAD CODE	
1/4-28	A
10-32	C
9/32-40	E
5/16-24	F
7mm COLLET	D

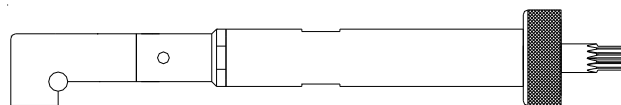

ATTACHMENT SHOWN WITH OPTIONAL  
3.750" 95.25mm G EXTENSION ASSEMBLY

PHONE: 775 883 1072 FAX: 775 883 4857

	A	B	C	D	90 DEGREE DRILL	
INCH	.362	.847	.625	3.550	MAXIMUM RECOMMENDED DRILL DIAMETER	.250
MM	9.19	21.5	15.87	90.17		6.35 mm



ALL BEARING LOW PROFILE 90 DEGREE DRILL ATTACHMENT

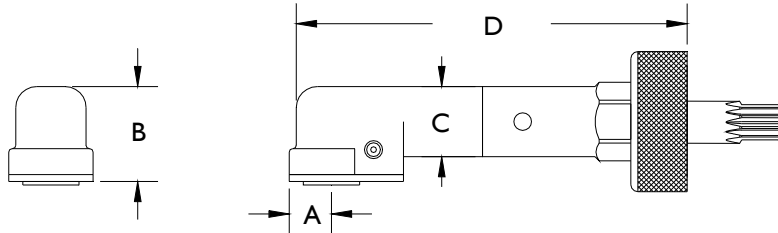

16500 ATTACHMENT ONLY  
PART OF THE JIFFY MODULAR DRILL SYSTEM



Shown with  
17639  
.85 HP 3000 RPM  
Straight Motor

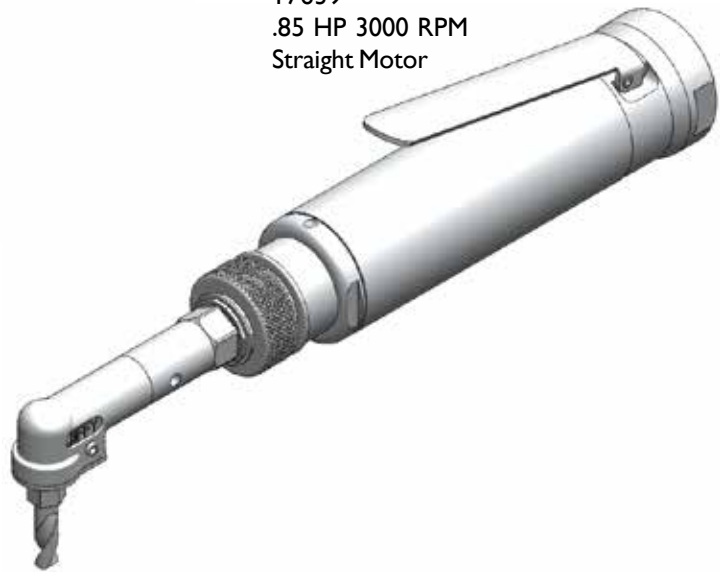

You must select an  
internal thread

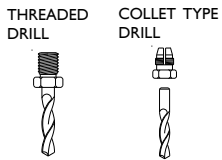

INTERNAL THREAD CODE	
1/4-28	A
10-32	C
9/32-40	E
7mm COLLET	D

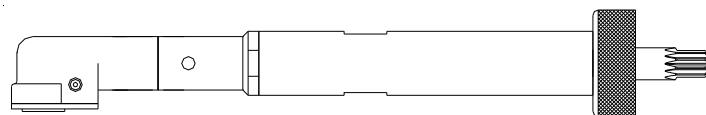

ATTACHMENT SHOWN WITH OPTIONAL  
3.750" 95.25mm G EXTENSION ASSEMBLY

PHONE: 775 883 1072 FAX: 775 883 4857



	A	B	C	D	90 DEGREE DRILL	
INCH	.362	.847	.625	2.750	MAXIMUM RECOMMENDED DRILL DIAMETER	.250
MM	9.19	21.5	15.87	69.85		6.35 mm



ALL BEARING LOW PROFILE 90 DEGREE DRILL ATTACHMENT

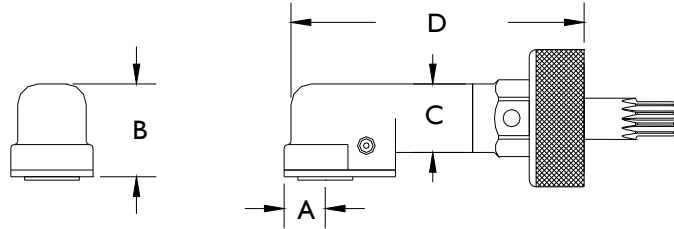

17945 ATTACHMENT ONLY  
PART OF THE JIFFY MODULAR DRILL SYSTEM

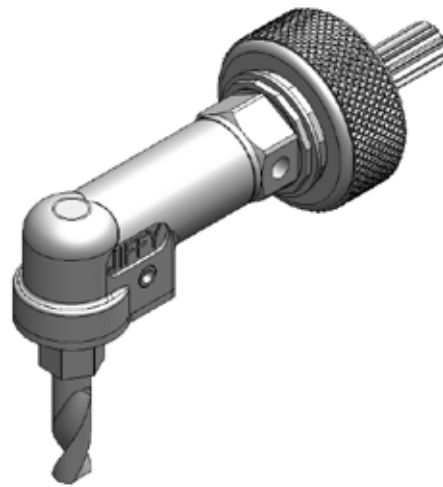

Shown with  
17639  
.85 HP 3000 RPM  
Straight Motor

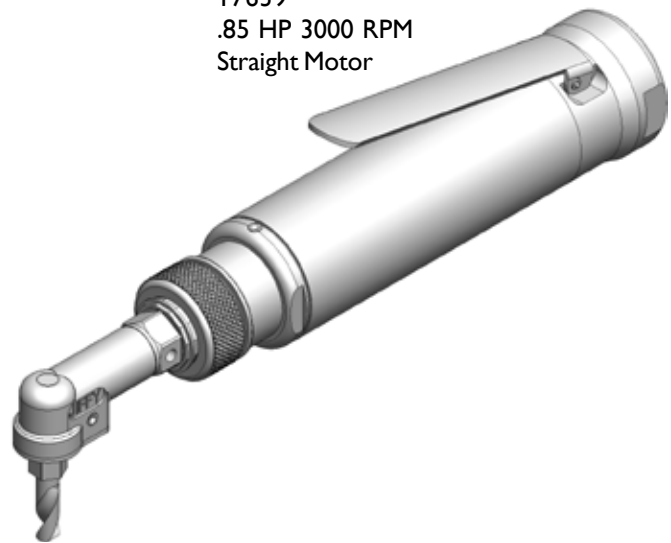

You must select an  
internal thread

THREADED  
DRILL



COLLET TYPE  
DRILL



INTERNAL THREAD CODE	
1/4-28	A
10-32	C
9/32-40	E
7mm COLLET	D

PHONE: 775 883 1072 FAX: 775 883 4857

	A	B	C	D	90 DEGREE DRILL	
INCH	.362	1.049	.625	3.550	MAXIMUM RECOMMENDED	.250
MM	9.19	26.64	15.87	90.17	DRILL DIAMETER	6.35 mm



ALL BEARING 90 DEGREE DRILL ATTACHMENT

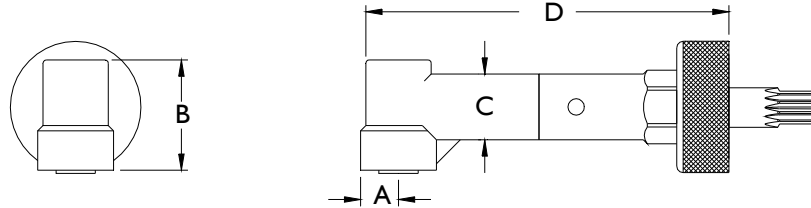

I4977 ATTACHMENT ONLY

PART OF THE JIFFY MODULAR DRILL SYSTEM

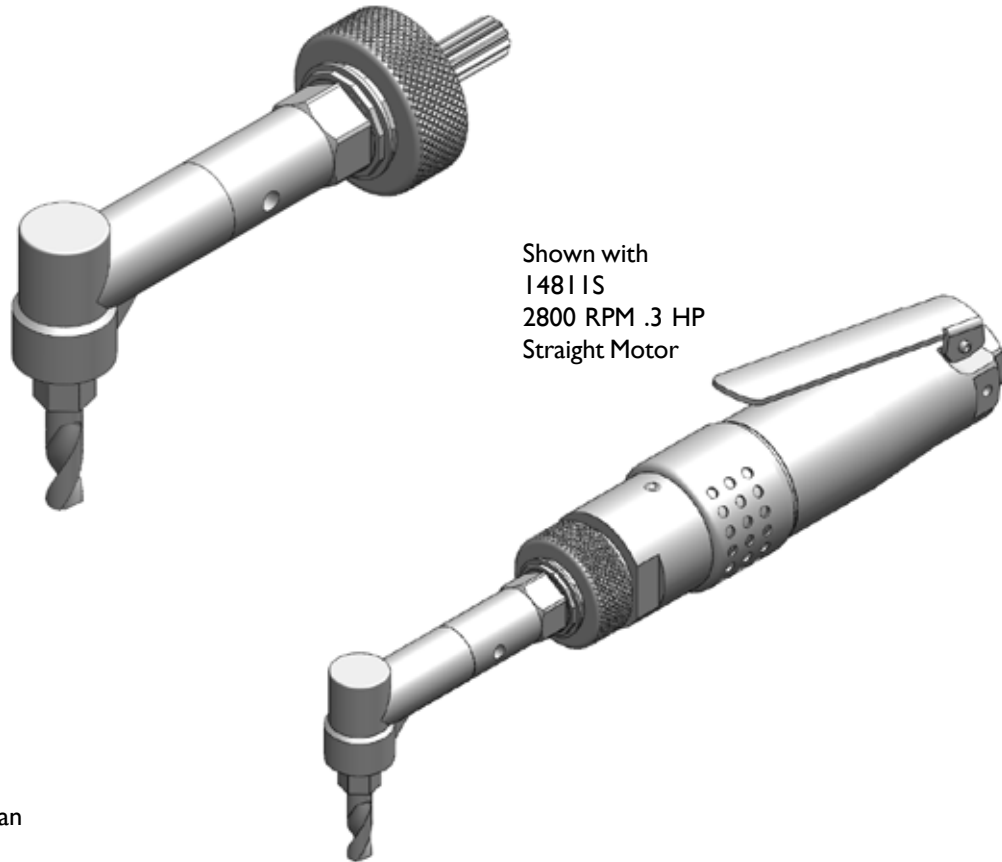

You must select an internal thread

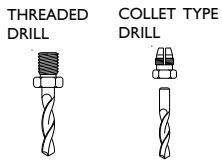

INTERNAL THREAD CODE	
1/4-28	A
10-32	C
9/32-40	E
7mm COLLET	D

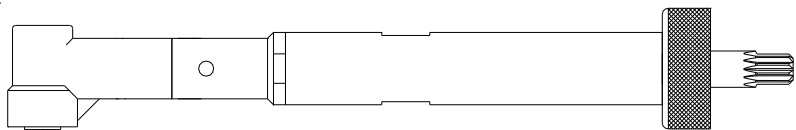

ATTACHMENT SHOWN WITH OPTIONAL 3.75" 95.25mm G EXTENSION ASSEMBLY

PHONE: 775 883 1072 FAX: 775 883 4857

	A	B	C	D	90 DEGREE DRILL	
INCH	.415	1.070	.900	3.800	MAXIMUM RECOMMENDED DRILL DIAMETER	.375
MM	10.54	27.17	22.8	96.5		9.52



**ALL BEARING SUPER DUTY 90 DEGREE DRILL ATTACHMENT**

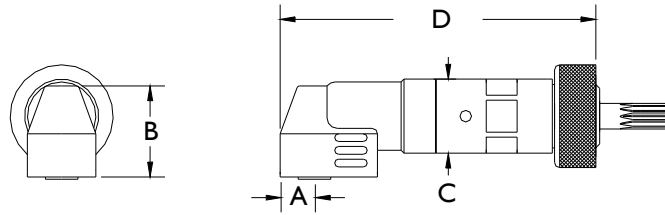

**18107 ATTACHMENT ONLY**  
PART OF THE JIFFY MODULAR DRILL SYSTEM

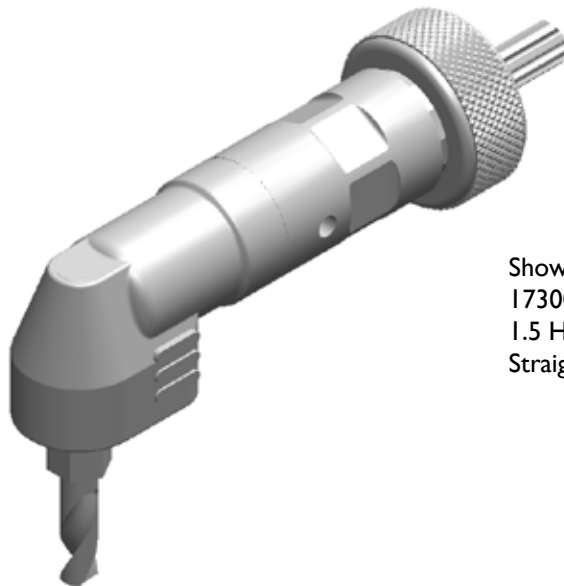

Shown with  
17300  
1.5 HP 6000 RPM  
Straight Motor

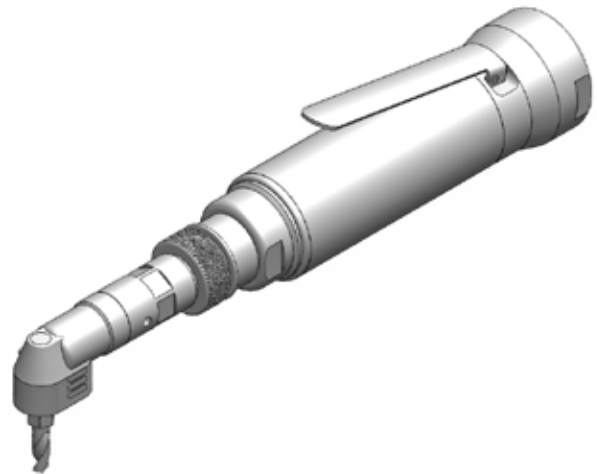

You must select  
an internal thread

THREADED  
DRILL

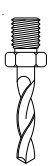

COLLET TYPE  
DRILL

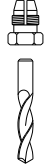

INTERNAL THREAD CODE	
1/4-28	A
9/32-40	E
5/16-24	F
3/8-24 FEMALE	Z
7mm COLLET	D
3/8-24 MALE	Y

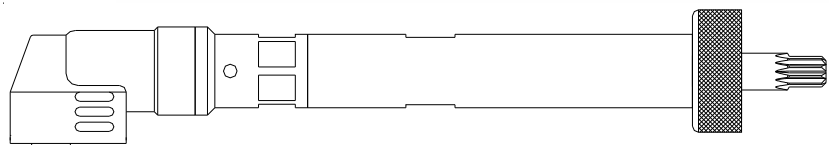

ATTACHMENT SHOWN WITH OPTIONAL  
3.750" 95.25mm G EXTENSION ASSEMBLY

PHONE: 775 883 1072 FAX: 775 883 4857

	A	B	C	D	45 DEGREE DRILL	
INCH	.312	.957	1.081	4.114	MAXIMUM RECOMMENDED DRILL DIAMETER	.250
MM	7.92	24.30	27.45	104.4		6.35 mm



45 DEGREE DRILL ATTACHMENT

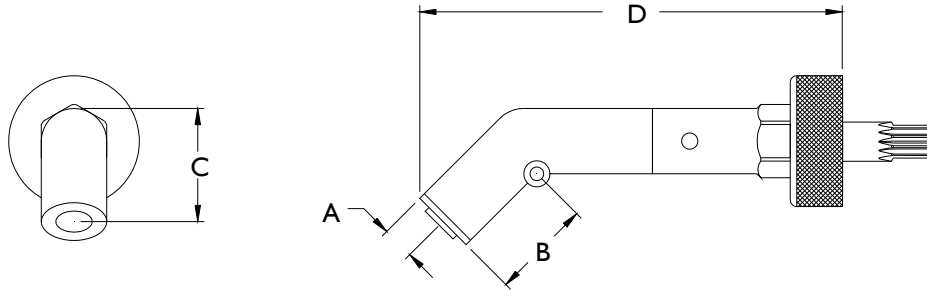

I4988 ATTACHMENT ONLY

PART OF THE JIFFY MODULAR DRILL SYSTEM

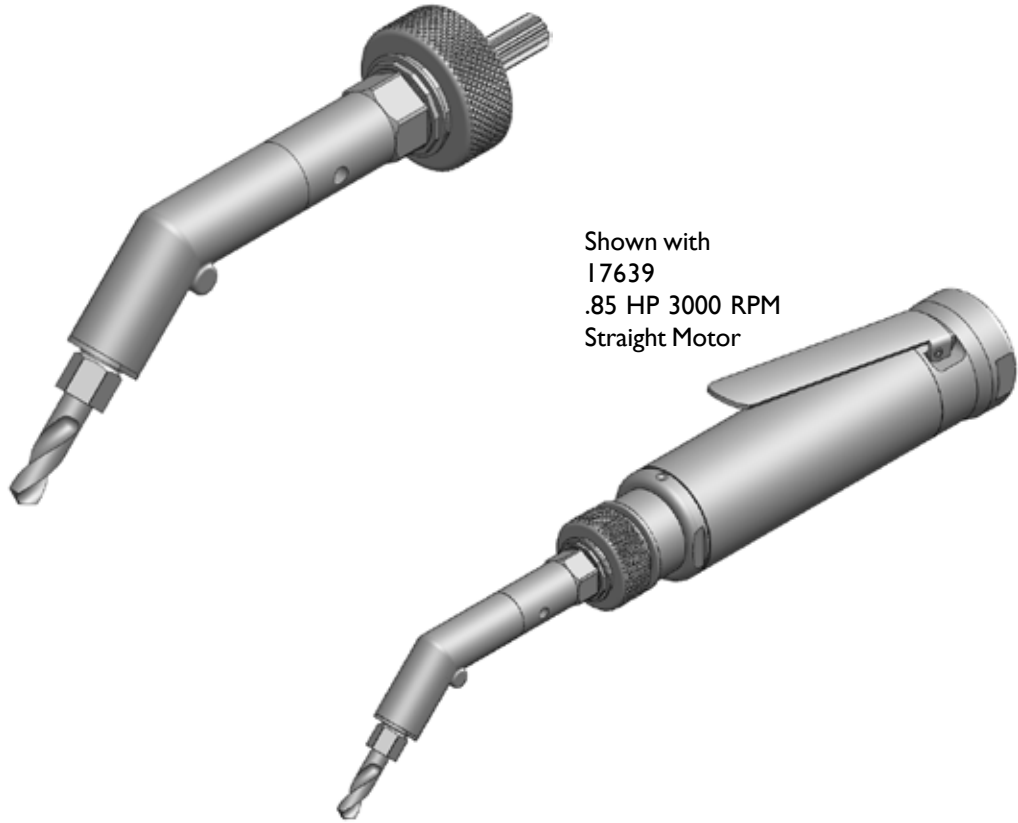

Shown with  
I7639  
.85 HP 3000 RPM  
Straight Motor

You must select an  
internal thread

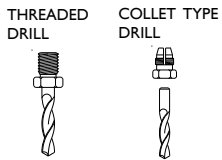

INTERNAL THREAD CODE	
1/4-28	A
10-32	C
9/32-40	E
5/16-24	F
7mm COLLET	D

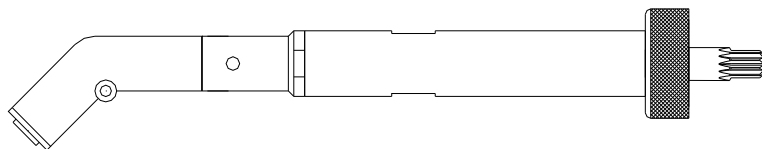

ATTACHMENT SHOWN WITH OPTIONAL  
3.750" 95.25mm G EXTENSION ASSEMBLY

PHONE: 775 883 1072 FAX: 775 883 4857

	A	B	C	D	E	45 DEGREE DRILL	
INCH	.450	1.458	.900	4.350	1.030	MAXIMUM RECOMMENDED DRILL DIAMETER	.375
MM	11.43	37.04	22.86	110.49	26.16		9.5 mm



ALL BEARING SUPER DUTY 45 DEGREE DRILL ATTACHMENT

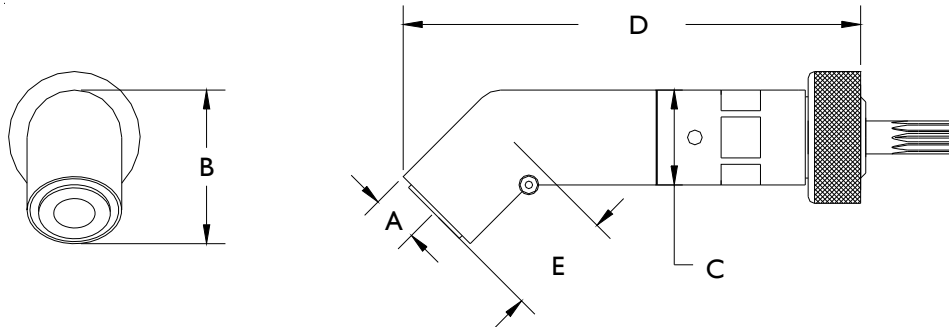

17596 ATTACHMENT ONLY  
PART OF THE JIFFY MODULAR DRILL SYSTEM

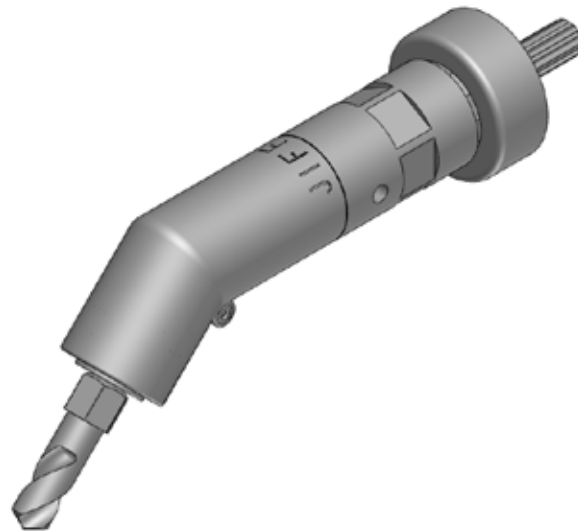

Shown with  
17300  
1.5 HP 6000 RPM  
Straight Motor

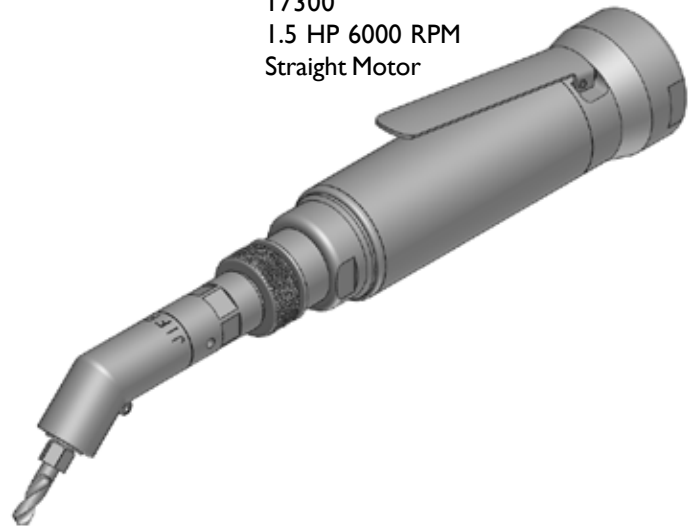

You must select an  
internal thread

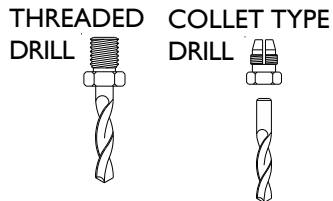

INTERNAL THREAD CODE	
1/4-28	A
9/32-40	E
5/16-24	F
3/8-24 FEMALE	Z
7mm COLLET	D
3/8-24 MALE	Y

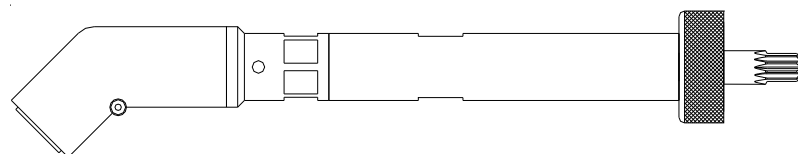

ATTACHMENT SHOWN WITH OPTIONAL  
3.750" 95.25mm G EXTENSION ASSEMBLY

PHONE: 775 883 1072    FAX: 775 883 4857

	A	B	C	D	360 DEGREE DRILL	
INCH	.362	1.049	3.162	3.550	MAXIMUM RECOMMENDED DRILL DIAMETER	.250
MM	9.19	26.64	80.31	90.17		6.35 mm



ALL BEARING 360 DEGREE DRILL ATTACHMENT

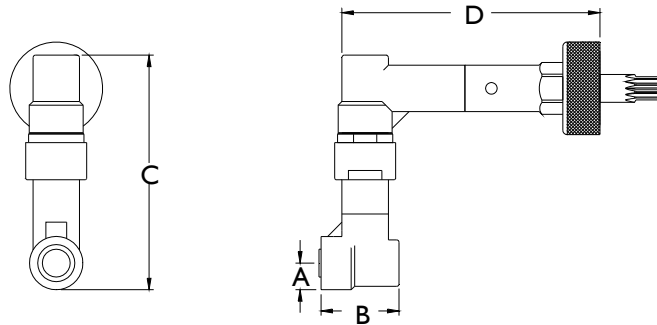

15000 ATTACHMENT ONLY  
PART OF THE JIFFY MODULAR DRILL SYSTEM

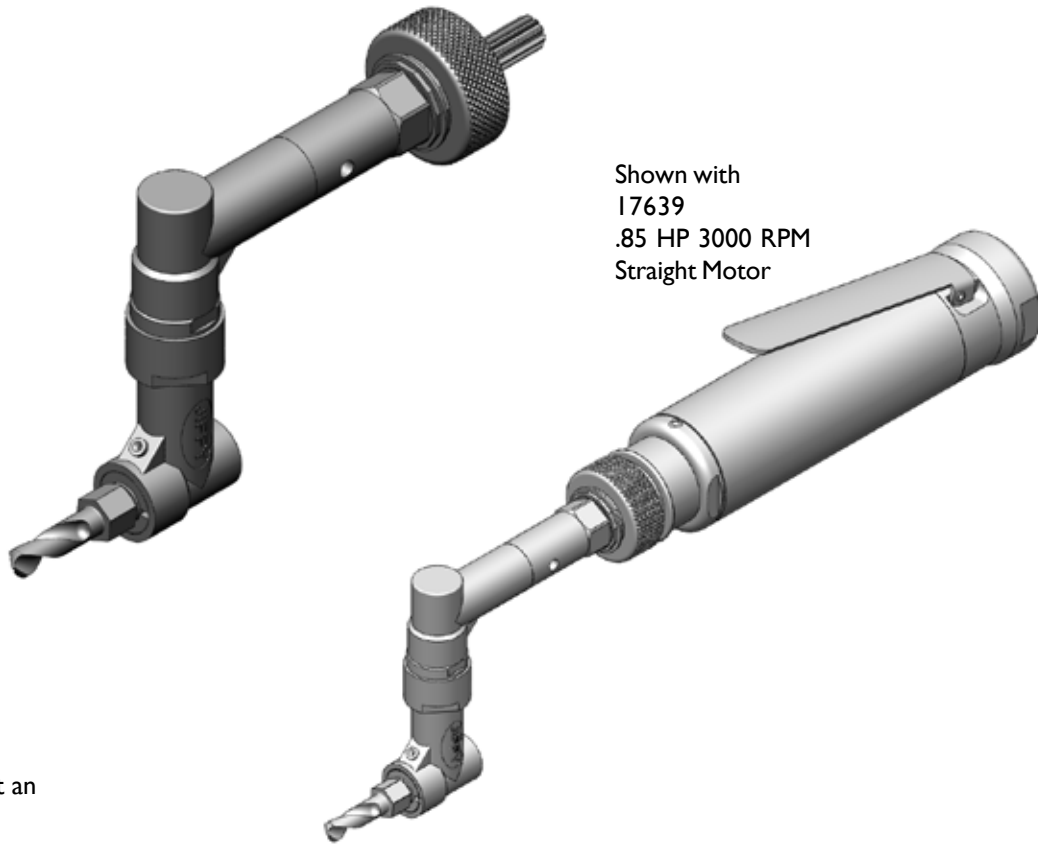

You must select an internal thread

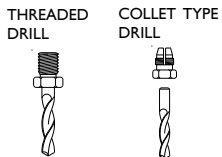

INTERNAL THREAD CODE	
1/4-28	A
10-32	C
9/32-40	E
7mm COLLET	D

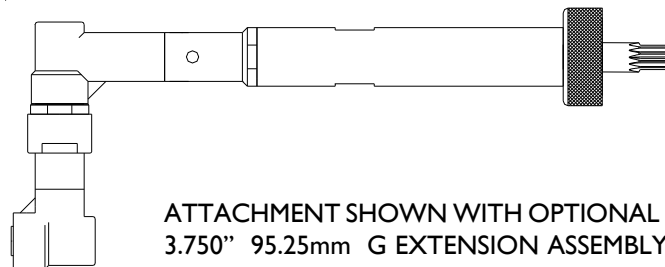

PHONE: 775 883 1072 FAX: 775 883 4857

	A	B	C	D	360 DEGREE DRILL	
INCH	.317	.937	3.137	3.550	MAXIMUM RECOMMENDED DRILL DIAMETER	.250
MM	8.05	23.7	79.67	90.17		6.35 mm



**LIMITED ACCESS 360 DEGREE ATTACHMENT**

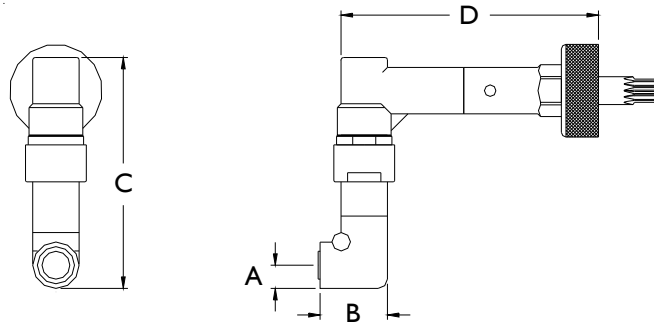

**15000M ATTACHMENT ONLY  
PART OF THE JIFFY MODULAR DRILL SYSTEM**

The output gear rides in a bushing instead of ball bearings.  
Attachment speed should be limited to 3000 RPM or less.

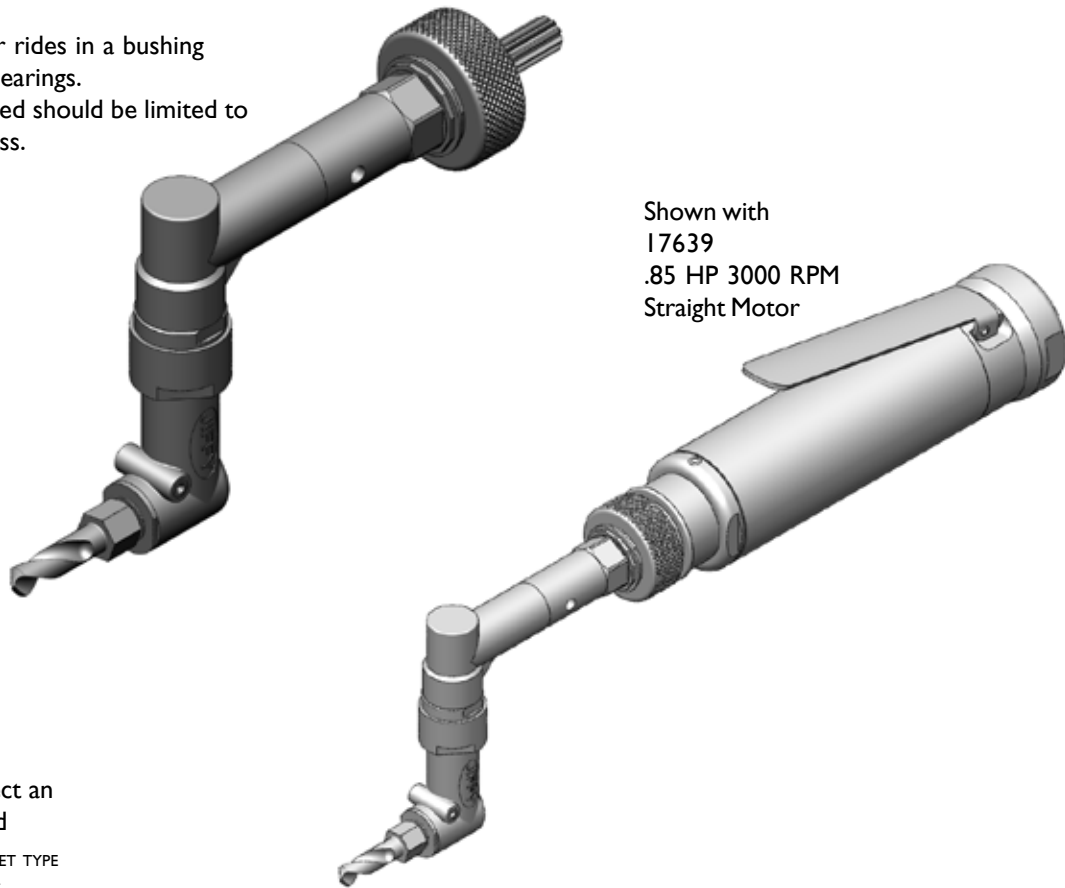

Shown with  
17639  
.85 HP 3000 RPM  
Straight Motor

You must select an internal thread

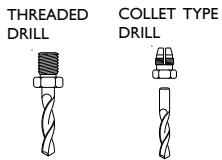

INTERNAL THREAD CODE	
1/4-28	A
10-32	C
9/32-40	E
5/16-24	F
7mm COLLET	D

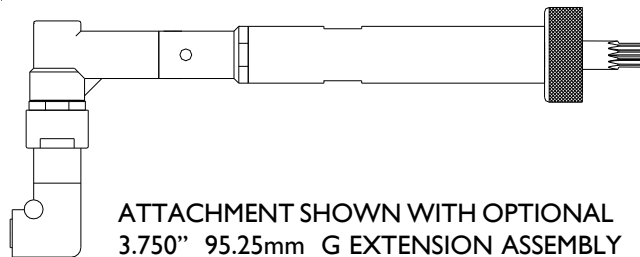

ATTACHMENT SHOWN WITH OPTIONAL  
3.750" 95.25mm G EXTENSION ASSEMBLY

PHONE: 775 883 1072 FAX: 775 883 4857

	A	B	C	D	E	SERIES I PANCAKE DRILL	
INCH	.250	1.042	2.027	.900	5.774	MAXIMUM RECOMMENDED DRILL DIAMETER	.1875
MM	6.35	26.46	51.48	22.86	146.6		4.76 mm



ALL BEARING INDEXABLE PANCAKE DRILLS

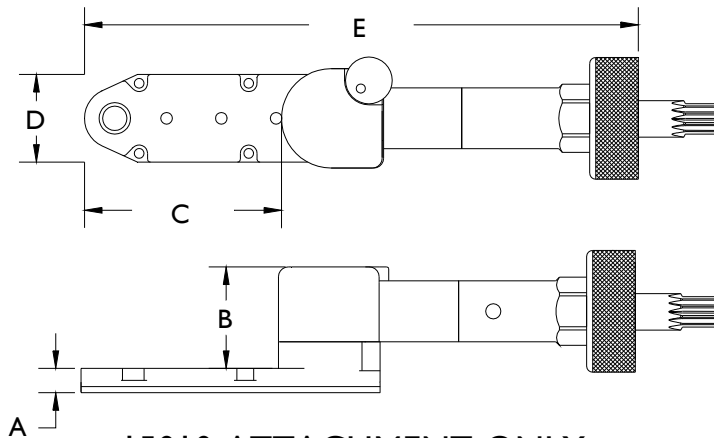

**I5010 ATTACHMENT ONLY**  
PART OF THE JIFFY MODULAR DRILL SYSTEM

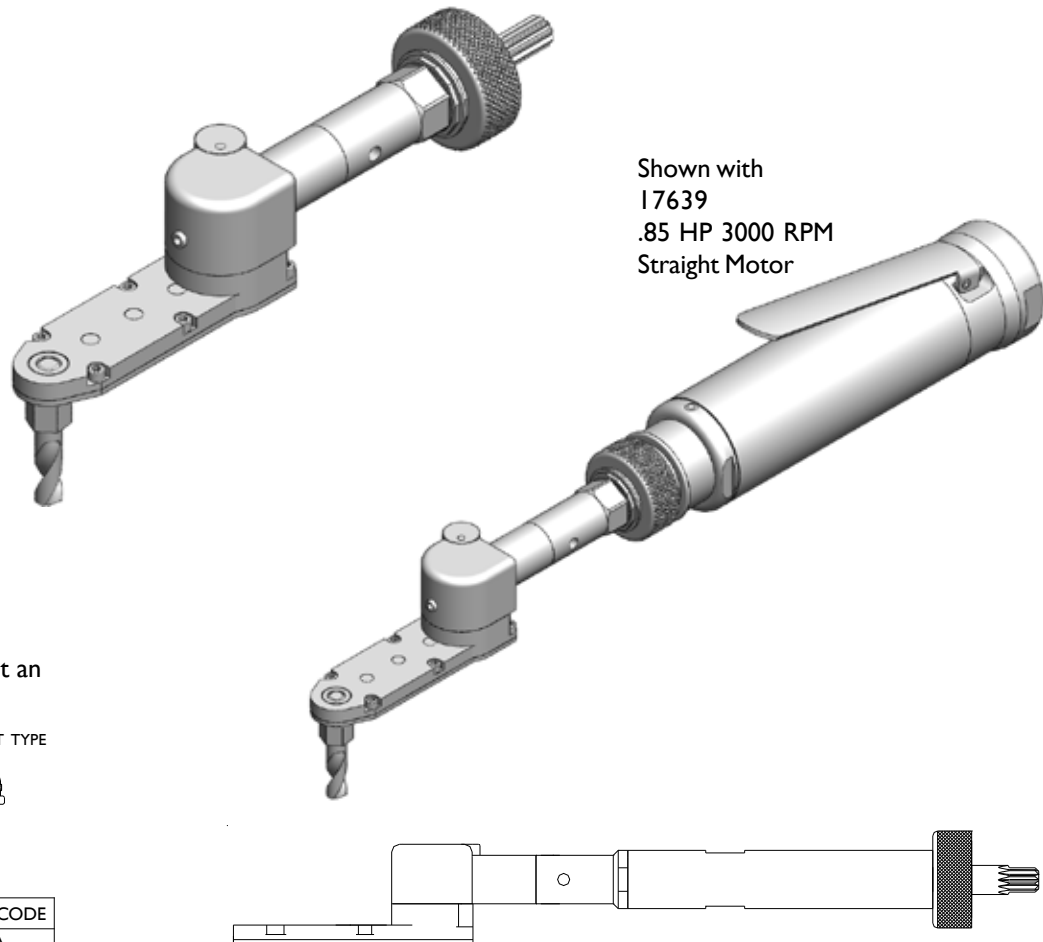

Shown with  
17639  
.85 HP 3000 RPM  
Straight Motor

You must select an  
internal thread

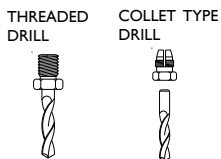

INTERNAL THREAD CODE	
1/4-28	A
10-32	C
9/32-40	E
5/16-24	F
7mm COLLET	D

ATTACHMENT SHOWN WITH OPTIONAL  
3.750" 95.25mm G EXTENSION ASSEMBLY

PHONE: 775 883 1072 FAX: 775 883 4857



	A	B	C	D	E	<b>SERIES I PANCAKE DRILL</b>	
INCH	.250	1.042	3.152	.900	6.899	MAXIMUM RECOMMENDED DRILL DIAMETER	.1875
MM	6.35	26.46	80.06	22.86	175.2		4.76 mm



**ALL BEARING INDEXABLE PANCAKE DRILLS**

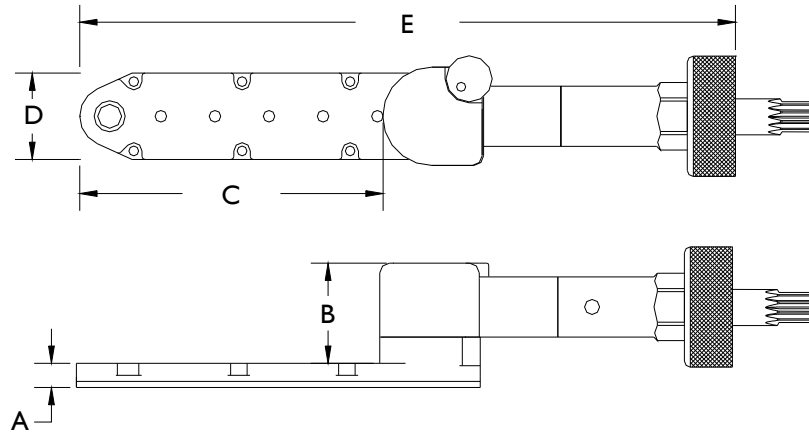

**16769 ATTACHMENT ONLY  
PART OF THE JIFFY MODULAR DRILL SYSTEM**

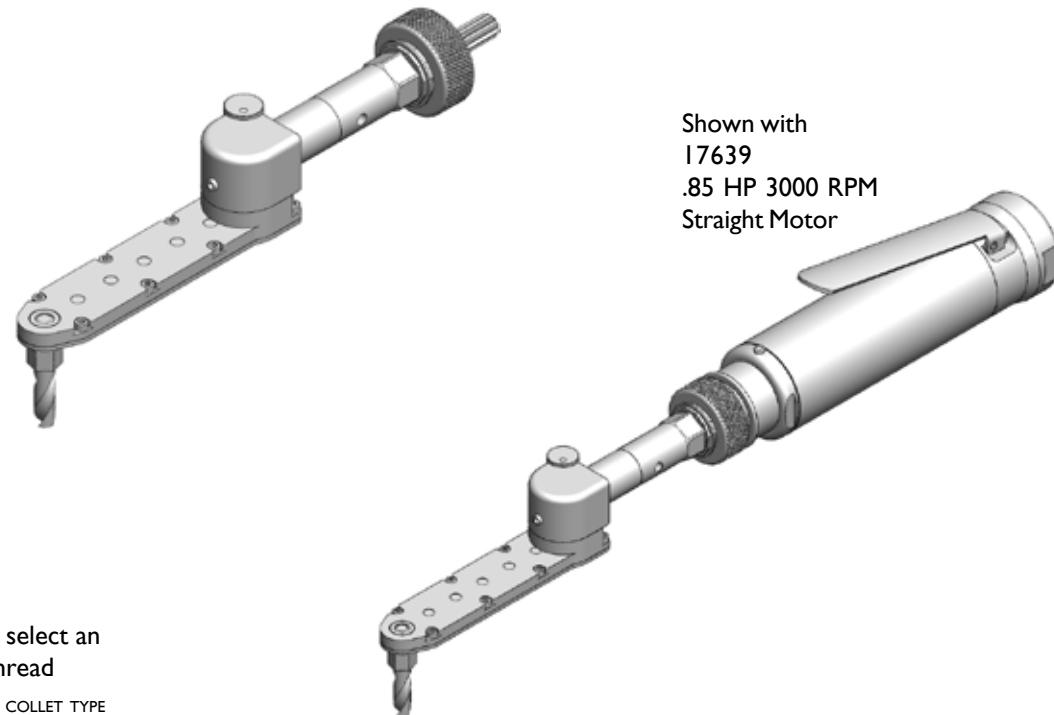

Shown with  
17639  
.85 HP 3000 RPM  
Straight Motor

You must select an  
internal thread

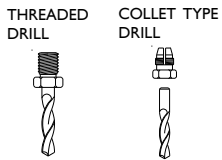

INTERNAL THREAD CODE	
1/4-28	A
10-32	C
9/32-40	E
5/16-24	F
7mm COLLET	D

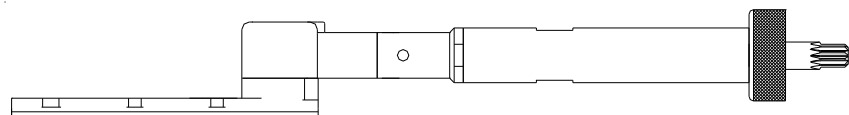

ATTACHMENT SHOWN WITH OPTIONAL  
3.750" 95.25mm G EXTENSION ASSEMBLY

PHONE: 775 883 1072 FAX: 775 883 4857

	A	B	C	D	E	SERIES 2 PANCAKE DRILL	
INCH	.350	.943	2.027	.900	5.774	MAXIMUM RECOMMENDED DRILL DIAMETER	.250
MM	8.89	23.95	51.48	22.86	146.6		6.35 mm



ALL BEARING INDEXABLE PANCAKE DRILLS

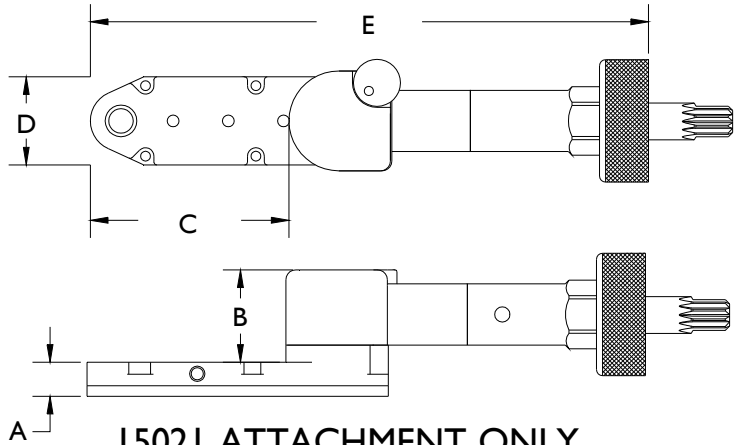

I502I ATTACHMENT ONLY  
PART OF THE JIFFY MODULAR DRILL SYSTEM

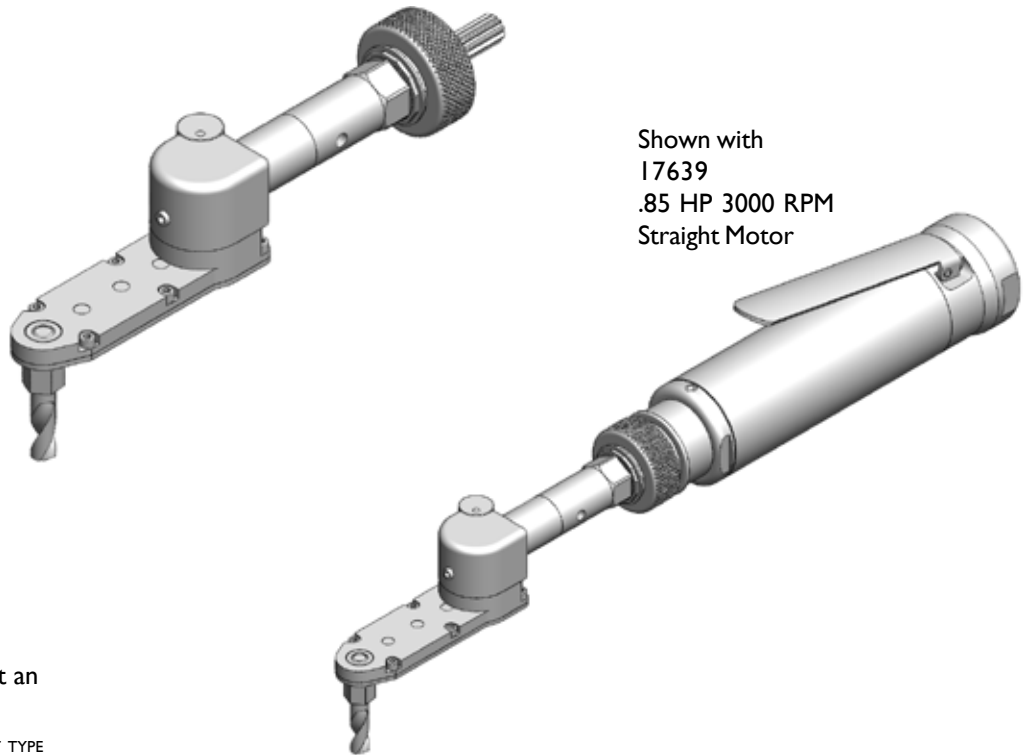

Shown with  
17639  
.85 HP 3000 RPM  
Straight Motor

You must select an  
internal thread

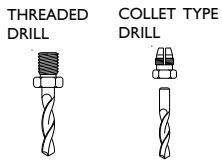

INTERNAL THREAD CODE	
1/4-28	A
10-32	C
9/32-40	E
5/16-24	F
7mm COLLET	D

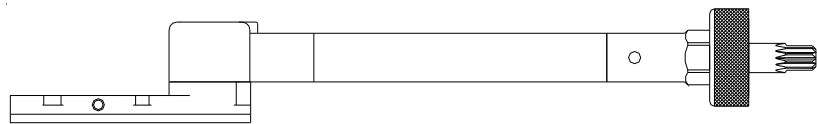

ATTACHMENT SHOWN WITH OPTIONAL  
3.750" 95.25mm G EXTENSION ASSEMBLY

PHONE: 775 883 1072 FAX: 775 883 4857

	A	B	C	D	E	<b>SERIES 2 PANCAKE DRILL</b>	
INCH	.350	1.042	3.152	.900	6.899	MAXIMUM RECOMMENDED DRILL DIAMETER	.250
MM	8.89	26.46	80.06	22.86	175.2		6.35 mm



**ALL BEARING INDEXABLE PANCAKE DRILLS**

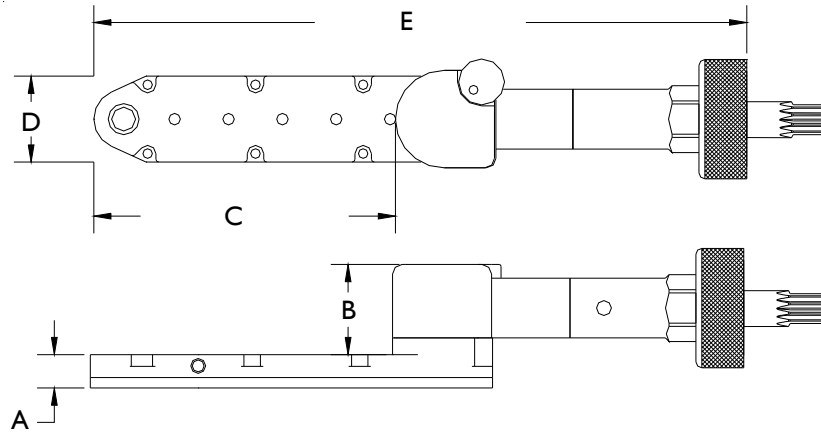

**17680 ATTACHMENT ONLY  
PART OF THE JIFFY MODULAR DRILL SYSTEM**

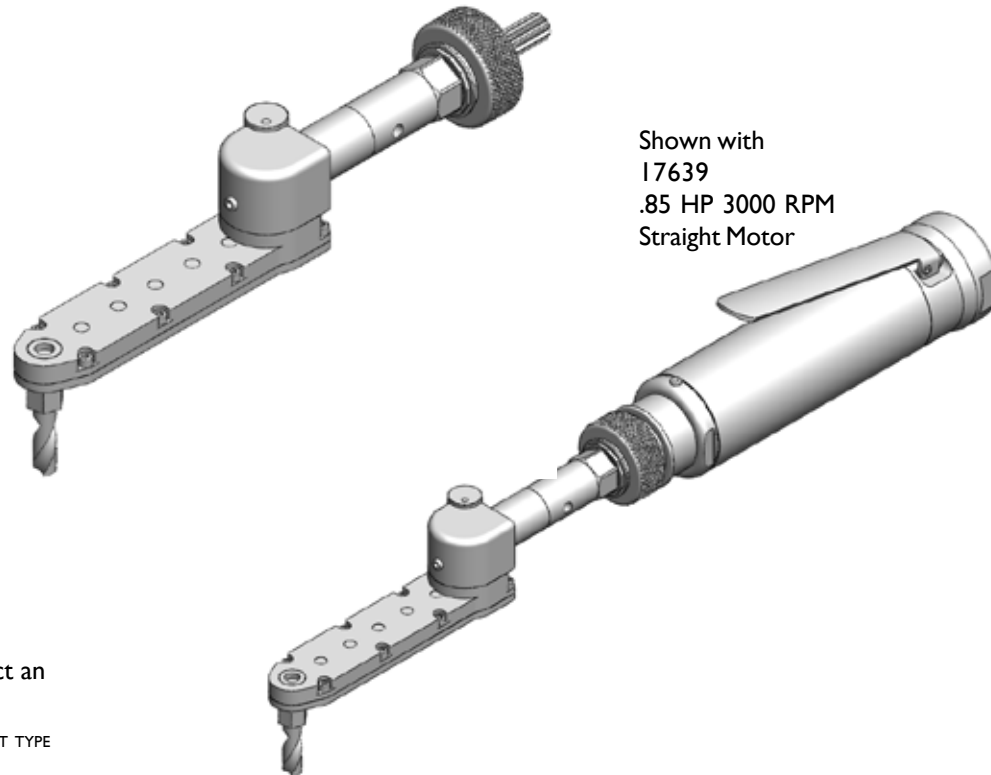

Shown with  
17639  
.85 HP 3000 RPM  
Straight Motor

You must select an  
internal thread

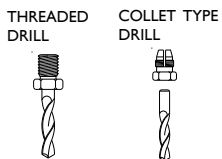

INTERNAL THREAD CODE	
1/4-28	A
10-32	C
9/32-40	E
5/16-24	F
7mm COLLET	D

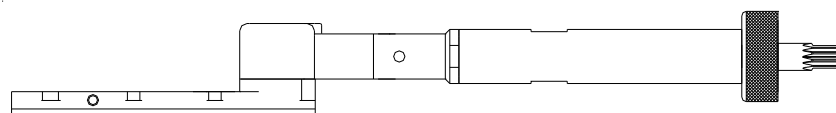

ATTACHMENT SHOWN WITH OPTIONAL  
3.750" 95.25mm G EXTENSION ASSEMBLY

PHONE: 775 883 1072 FAX: 775 883 4857

	A	B	C	D	E	SERIES 4 PANCAKE DRILL	
INCH	.500	1.15	3.03	1.12	7.1	MAXIMUM RECOMMENDED DRILL DIAMETER	.375
MM	12.7	29.2	76.9	28.4	180.3		9.52 mm



ALL BEARING INDEXABLE PANCAKE DRILLS

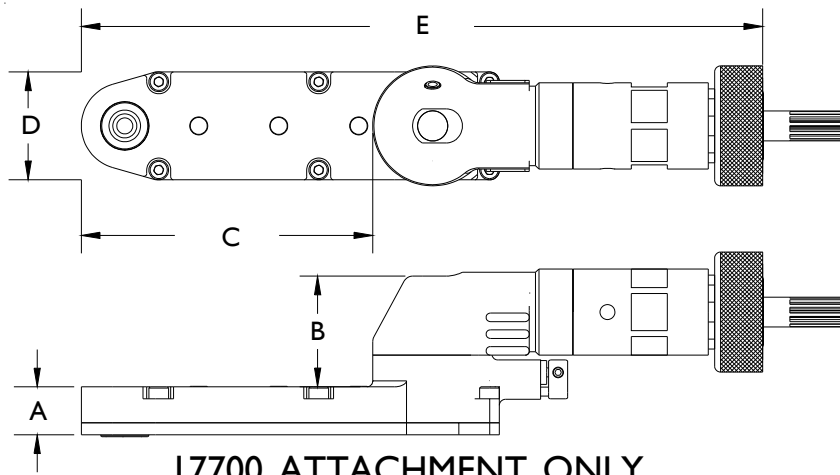

17700 ATTACHMENT ONLY  
PART OF THE JIFFY MODULAR DRILL SYSTEM

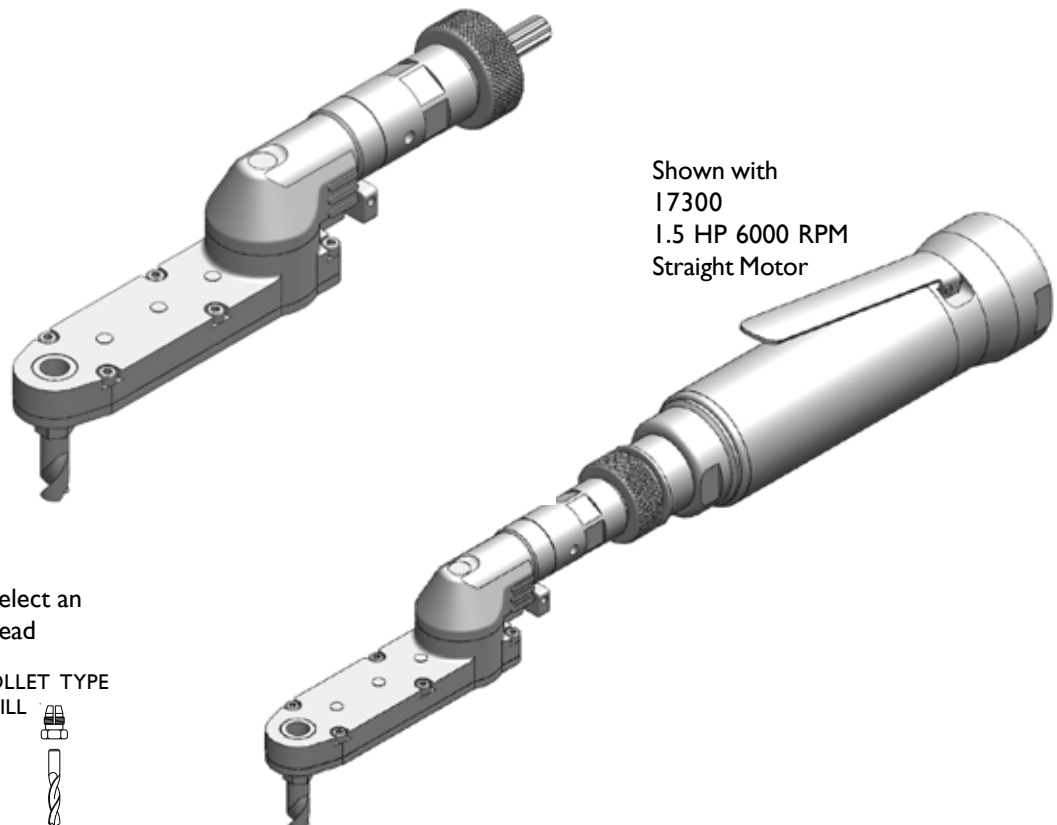

You must select an internal thread

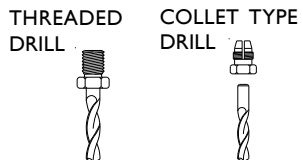

INTERNAL THREAD CODE	
1/4-28	A
9/32-40	E
5/16-24	F
3/8-24	Z
7mm COLLET	D
3/8-24 MALE	Y

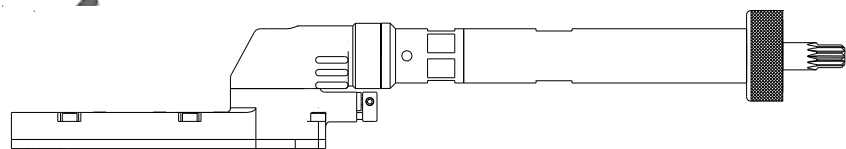

ATTACHMENT SHOWN WITH OPTIONAL  
3.750" 95.25mm G EXTENSION ASSEMBLY

PHONE: 775 883 1072 FAX: 775 883 4857

	A	B	C	D	E	SERIES 4 PANCAKE DRILL	
INCH	.500	1.15	4.69	1.12	8.76	MAXIMUM RECOMMENDED DRILL DIAMETER	.375
MM	12.7	29.2	119.1	28.4	222.5		9.52 mm



ALL BEARING INDEXABLE PANCAKE DRILLS

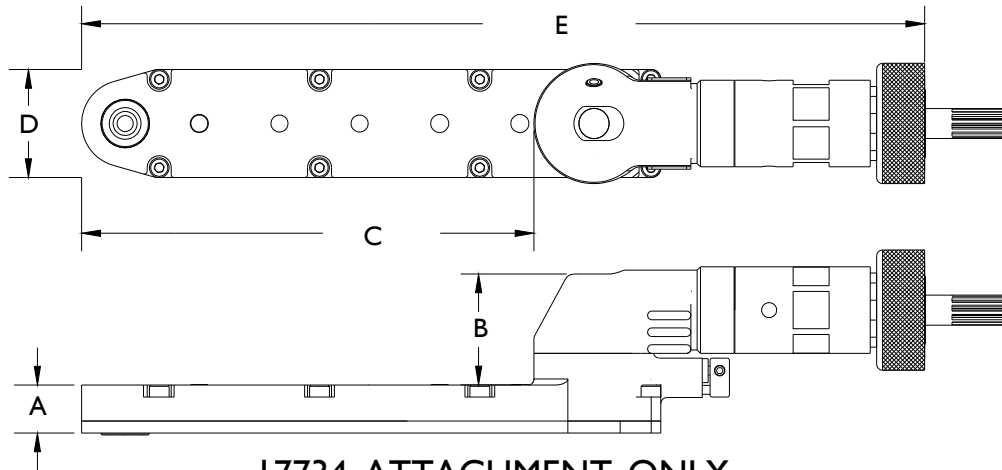

17734 ATTACHMENT ONLY  
PART OF THE JIFFY MODULAR DRILL SYSTEM

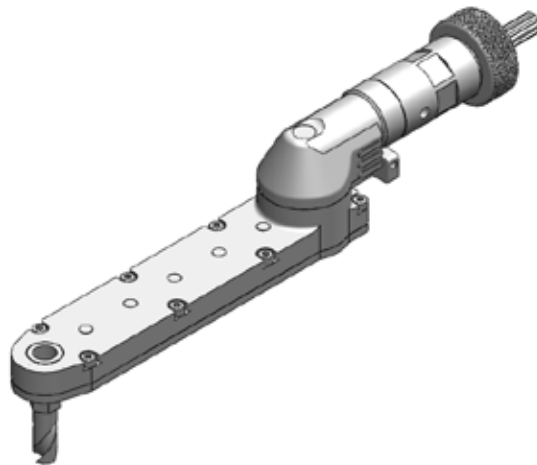

Shown with  
17300  
1.5 HP 6000 RPM  
Straight Motor

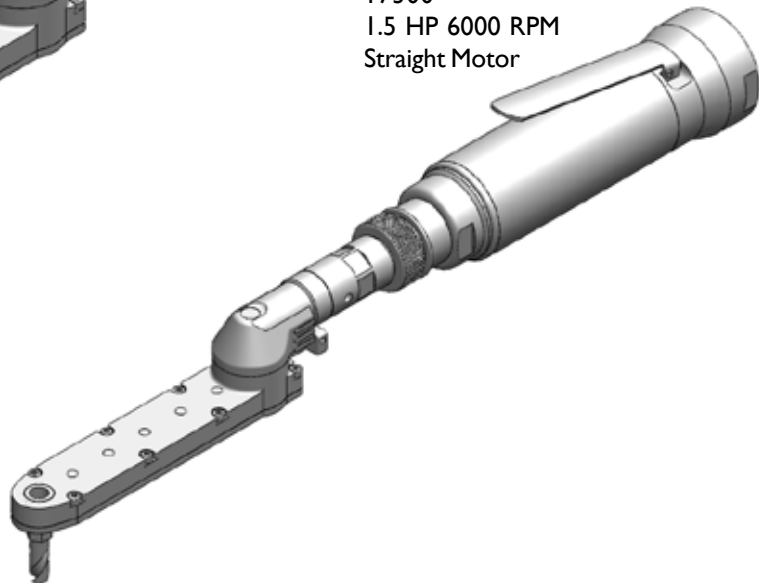

You must select an  
internal thread

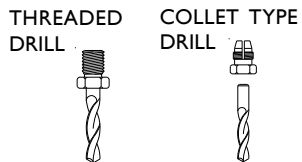

INTERNAL THREAD CODE	
1/4-28	A
9/32-40	E
5/16-24	F
3/8-24	Z
7mm COLLET	D
3/8-24 MALE	Y

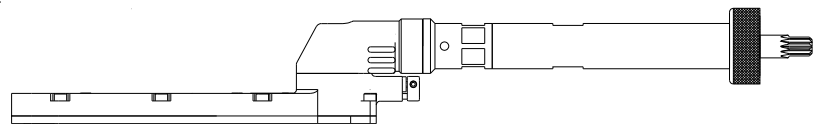

ATTACHMENT SHOWN WITH OPTIONAL  
3.75" 95.25mm G EXTENSION ASSEMBLY

PHONE: 775 883 1072 FAX: 775 883 4857

	A	B	C	D	E	SERIES 4 PANCAKE DRILL	
INCH	.500	1.15	6.36	1.12	10.43	MAXIMUM RECOMMENDED DRILL DIAMETER	.375
MM	12.7	29.2	161.5	28.4	264.9		9.52 mm



ALL BEARING INDEXABLE PANCAKE DRILLS

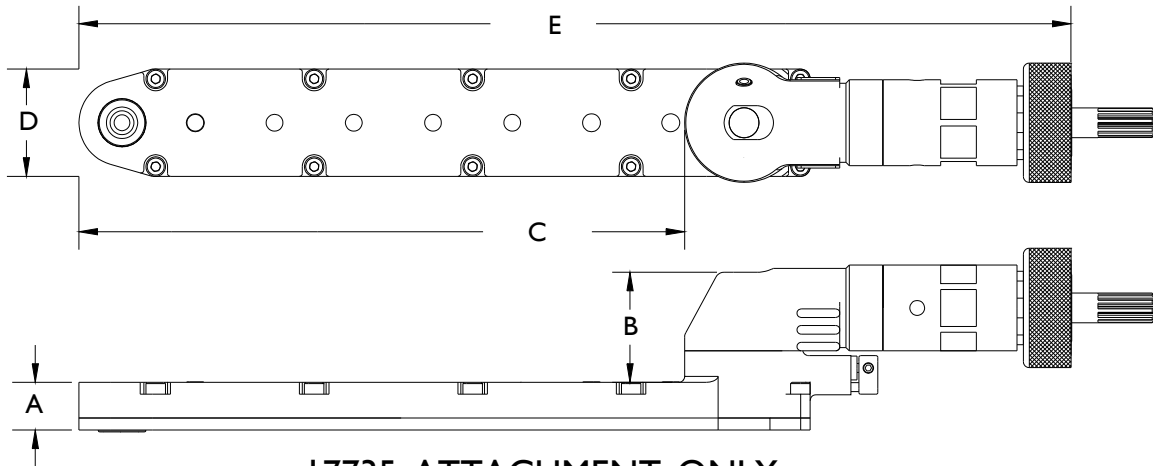

17735 ATTACHMENT ONLY  
PART OF THE JIFFY MODULAR DRILL SYSTEM

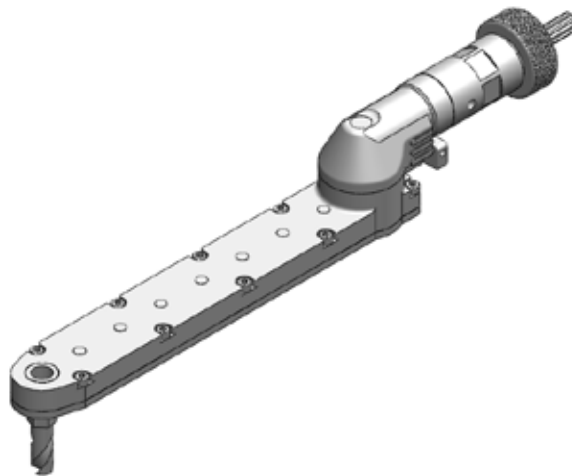

Shown with  
17300  
1.5 HP 6000 RPM  
Straight Motor

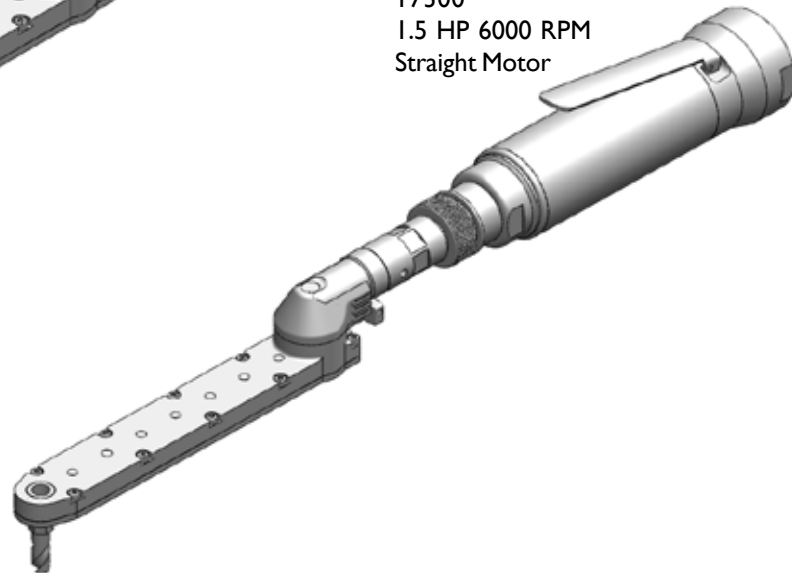

You must select an  
internal thread

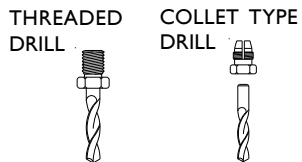

INTERNAL THREAD CODE	
1/4-28	A
9/32-40	E
5/16-24	F
3/8-24	Z
7mm COLLET	D
3/8-24 MALE	Y

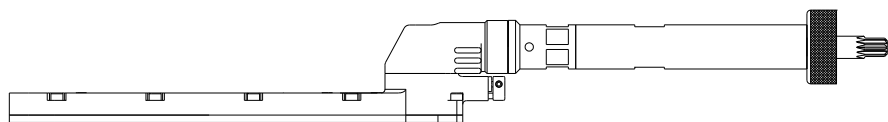

ATTACHMENT SHOWN WITH OPTIONAL  
3.750" 95.25mm G EXTENSION ASSEMBLY

PHONE: 775 883 1072 FAX: 775 883 4857

	A	B	C	D	E	F	G	H	SERIES I 17 DEGREE DRILL	
INCH	.250	2.23	3.1	.90	1.02	.327	1.68	1.10	MAXIMUM RECOMMENDED	.1875 INCH
MM	6.35	56.06	78.7	22.8	25.9	6.01	42.6	27.9	DRILL DIAMETER	4.76 mm



## SERIES I INDEXABLE 17 DEGREE DRILLS

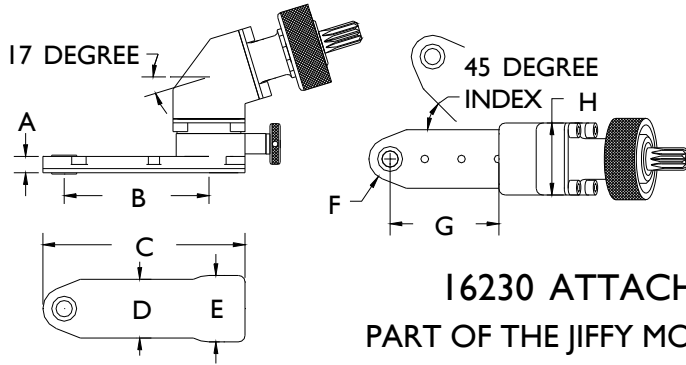

**I6230 ATTACHMENT ONLY**  
PART OF THE JIFFY MODULAR DRILL SYSTEM

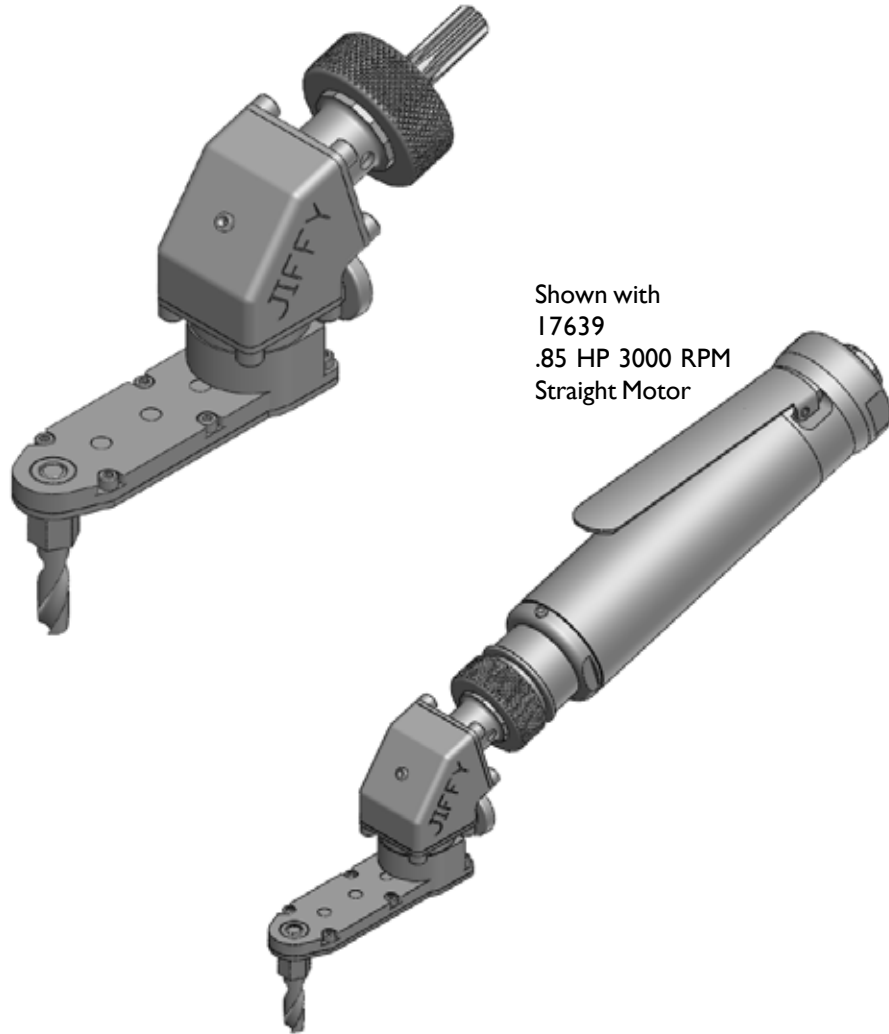

You must select an internal thread

THREADED DRILL



COLLET TYPE DRILL



INTERNAL THREAD CODE	
1/4-28	A
10-32	C
9/32-40	E
5/16-24	F
7mm COLLET	D

PHONE: 775 883 1072 FAX: 775 883 4857

	A	B	C	D	E	F	G	H	SERIES I 17 DEGREE DRILL	
INCH	.250	3.35	4.22	.90	1.02	.327	2.80	1.10	MAXIMUM RECOMMENDED	.1875 INCH
MM	6.35	85.2	107.3	22.8	25.9	6.01	71.1	27.9	DRILL DIAMETER	4.76 mm



## SERIES I INDEXABLE 17 DEGREE DRILLS

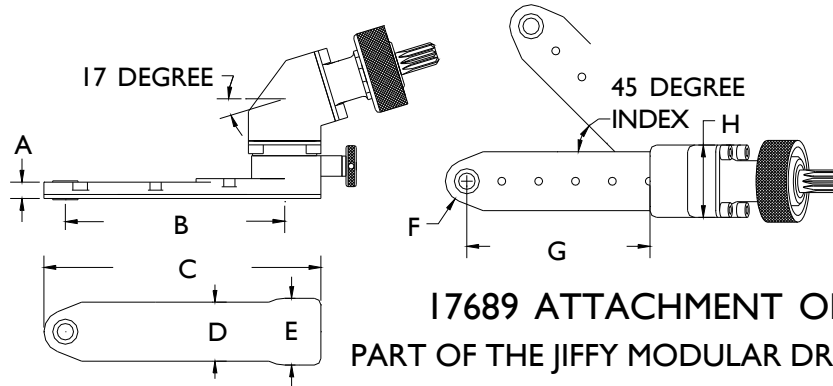

**17689 ATTACHMENT ONLY**  
PART OF THE JIFFY MODULAR DRILL SYSTEM

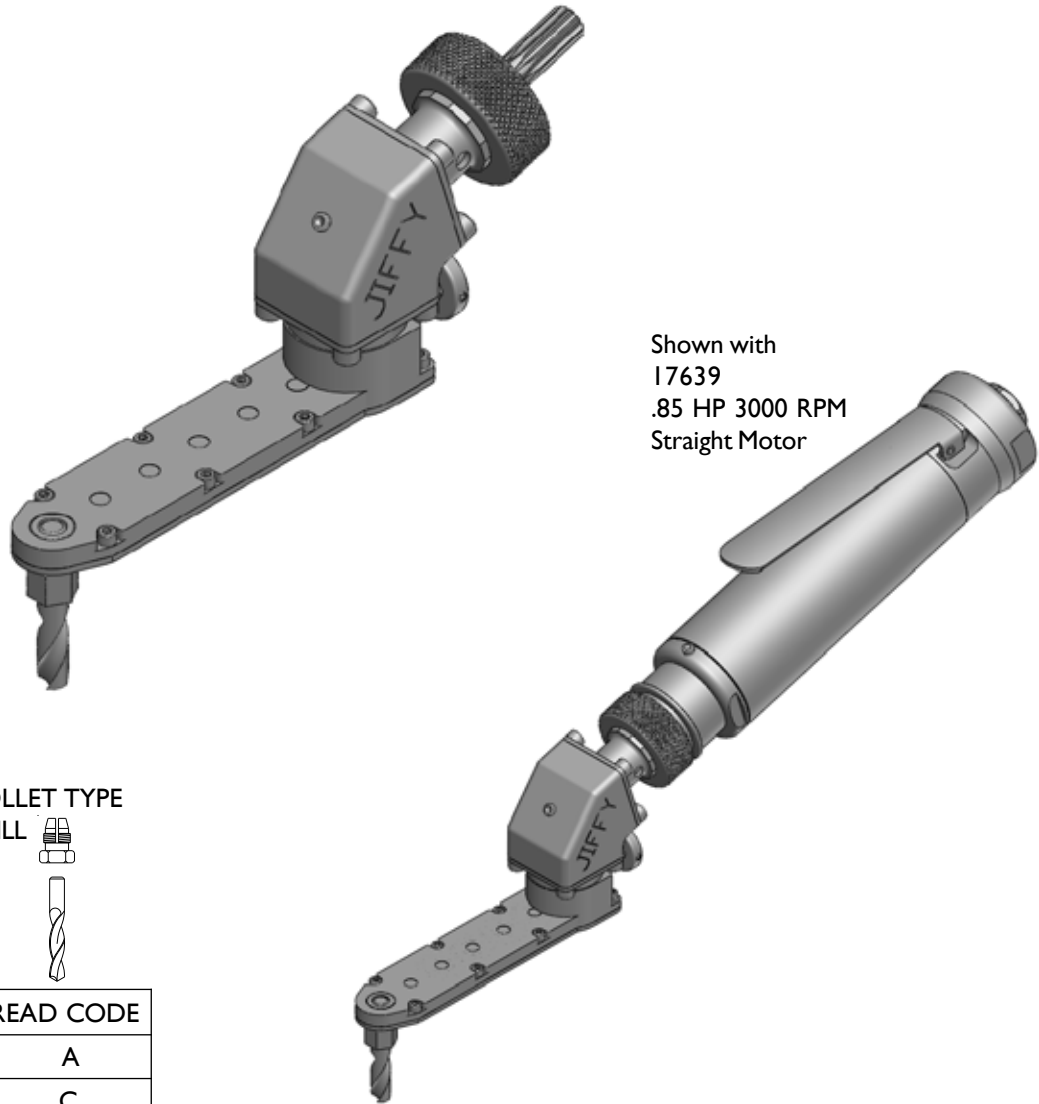

Shown with  
17639  
.85 HP 3000 RPM  
Straight Motor

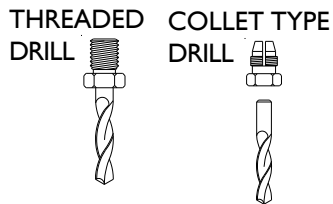

INTERNAL THREAD CODE	
1/4-28	A
10-32	C
9/32-40	E
5/16-24	F
7mm COLLET	D

PHONE: 775 883 1072 FAX: 775 883 4857



	A	B	C	D	E	F	G	H	SERIES I 17 DEGREE DRILL	
INCH	.250	4.48	5.35	.90	1.02	.327	3.93	1.10	MAXIMUM RECOMMENDED	.1875 INCH
MM	6.35	113.8	135.9	22.8	25.9	8.3	99.8	27.9	DRILL DIAMETER	4.76 mm



## SERIES I INDEXABLE 17 DEGREE DRILLS

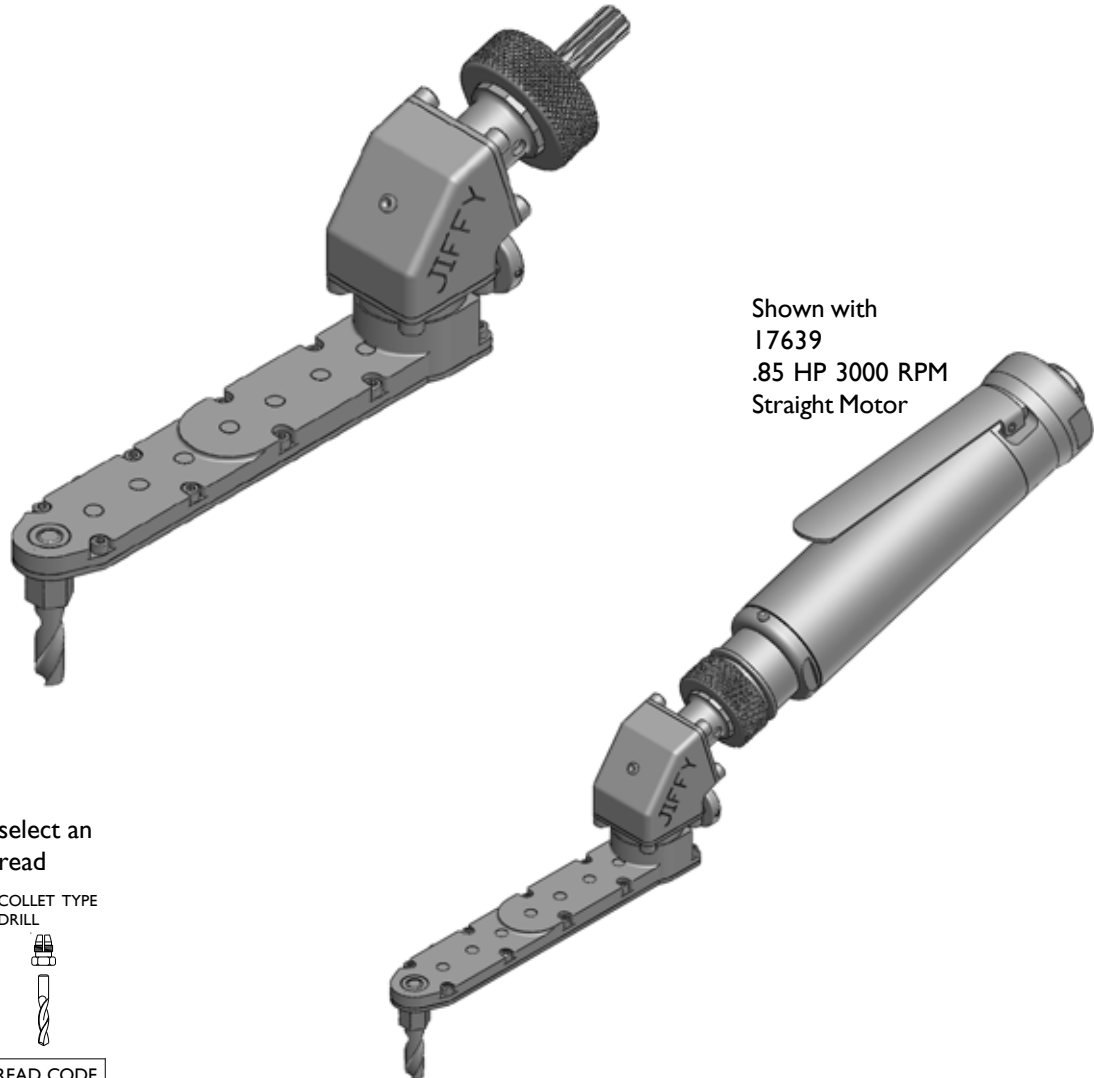
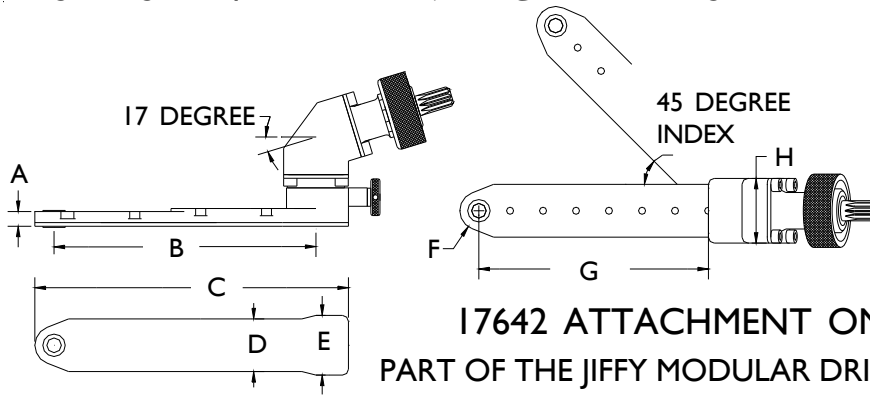

You must select an internal thread

THREADED DRILL



COLLET TYPE DRILL



INTERNAL THREAD CODE	
1/4-28	A
10-32	C
9/32-40	E
5/16-24	F
7mm COLLET	D

PHONE: 775 883 1072 FAX: 775 883 4857

	A	B	C	D	E	F	G	H	SERIES 2 17 DEGREE DRILL	
INCH	.350	2.23	3.1	.90	1.02	.327	1.68	1.10	MAXIMUM RECOMMENDED	.250 INCH
MM	8.89	56.6	78.7	22.8	25.9	8.3	42.6	27.9	DRILL DIAMETER	6.35 mm



## SERIES 2 INDEXABLE 17 DEGREE DRILLS

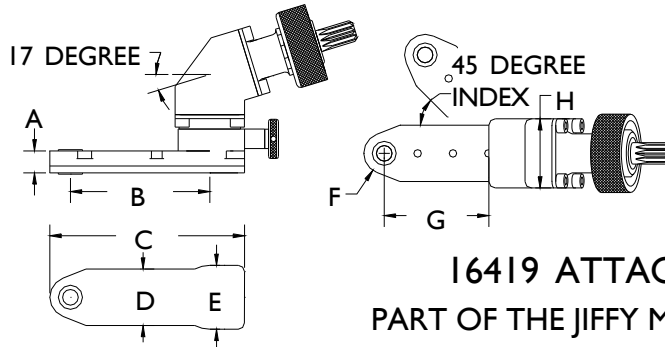

16419 ATTACHMENT ONLY  
PART OF THE JIFFY MODULAR DRILL SYSTEM

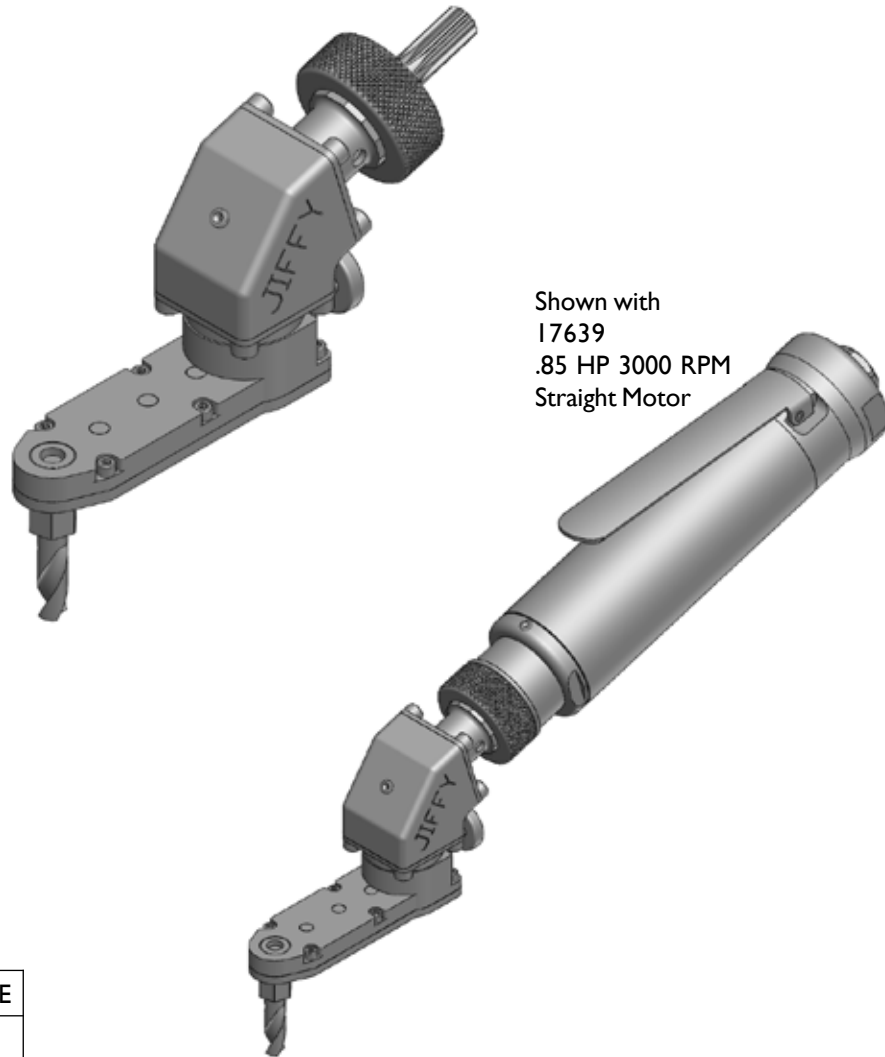

Shown with  
17639  
.85 HP 3000 RPM  
Straight Motor

You must select an  
internal thread

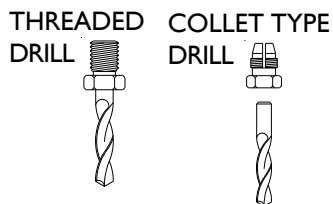

INTERNAL THREAD CODE	
1/4-28	A
10-32	C
9/32-40	E
5/16-24	F
7mm COLLET	D

PHONE: 1 775 883 1072 FAX: 1 775 883 4857

	A	B	C	D	E	F	G	H	SERIES 2 17 DEGREE DRILL	
INCH	.350	3.35	4.22	.90	1.02	.327	2.80	1.10	MAXIMUM RECOMMENDED DRILL DIAMETER	.250 INCH
MM	8.89	85	107.1	22.8	25.9	8.3	71.1	27.9		6.35 mm



## SERIES 2 INDEXABLE 17 DEGREE DRILLS

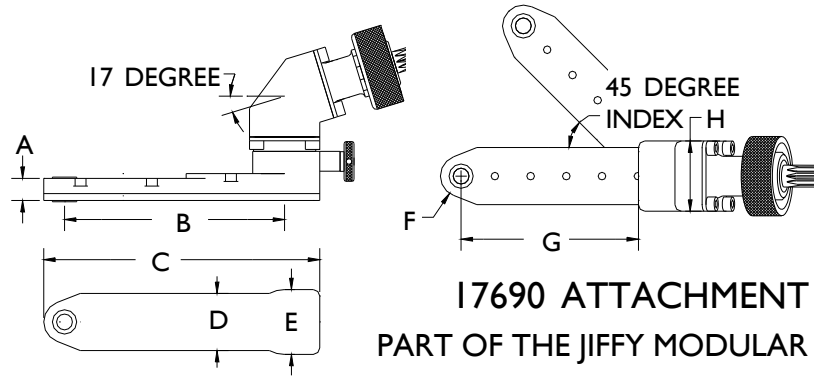

**17690 ATTACHMENT ONLY**  
PART OF THE JIFFY MODULAR DRILL SYSTEM

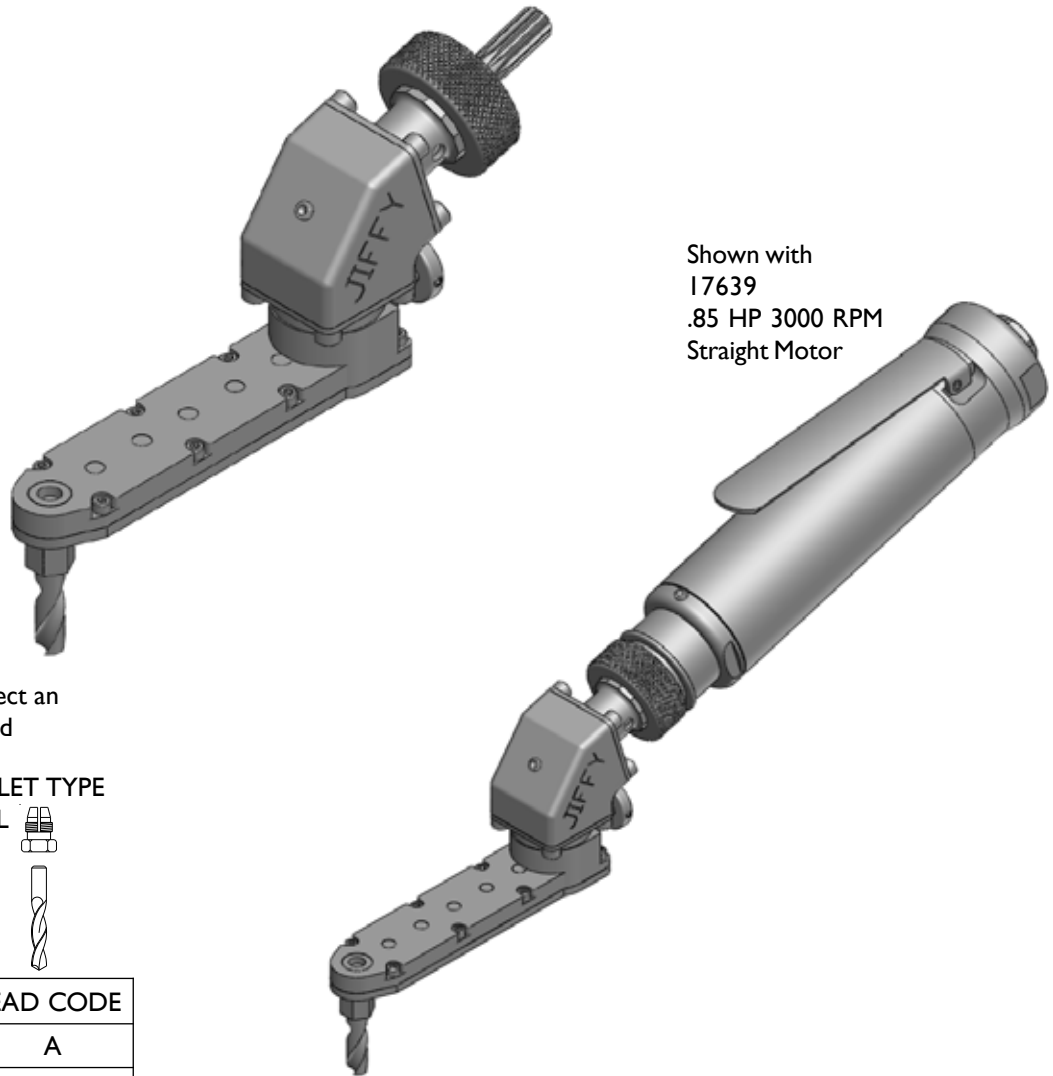

You must select an internal thread

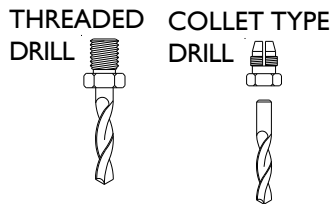

INTERNAL THREAD CODE	
1/4-28	A
10-32	C
9/32-40	E
5/16-24	F
7mm COLLET	D

PHONE: 1 775 883 1072 FAX: 1 775 883 4857

	A	B	C	D	E	F	G	H	SERIES 2 17 DEGREE DRILL	
INCH	.350	4.48	5.35	.90	1.02	.327	3.93	1.10	MAXIMUM RECOMMENDED	.250 INCH
MM	8.89	113.8	135.9	22.8	25.9	8.3	99.8	27.9	DRILL DIAMETER	6.35 mm



## SERIES 2 INDEXABLE 17 DEGREE DRILLS

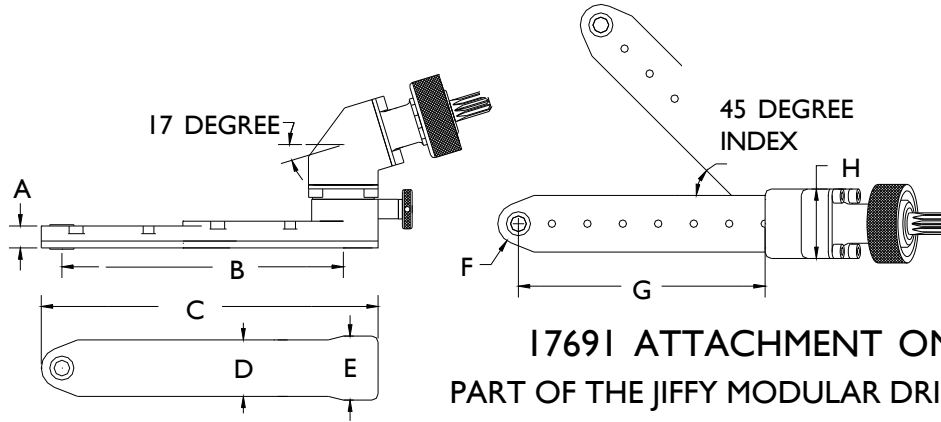

**1769I ATTACHMENT ONLY**  
PART OF THE JIFFY MODULAR DRILL SYSTEM

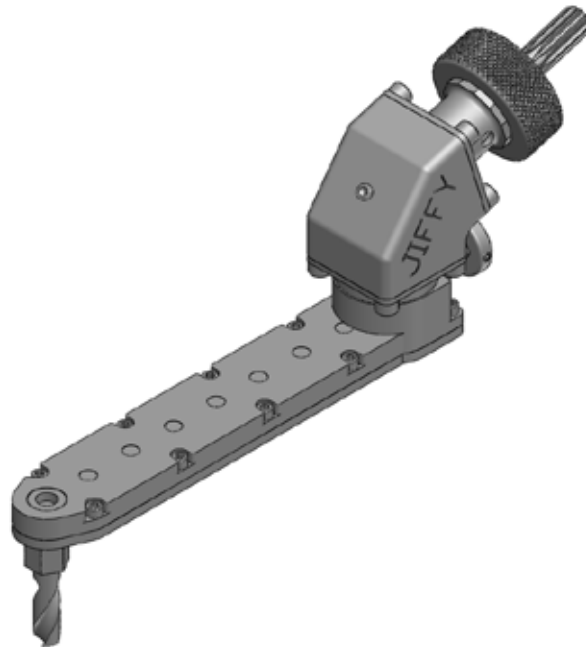

Shown with  
17639  
.85 HP 3000 RPM  
Straight Motor

You must select an  
internal thread

THREADED  
DRILL



COLLET TYPE  
DRILL



INTERNAL THREAD CODE	
1/4-28	A
10-32	C
9/32-40	E
5/16-24	F
7mm COLLET	D

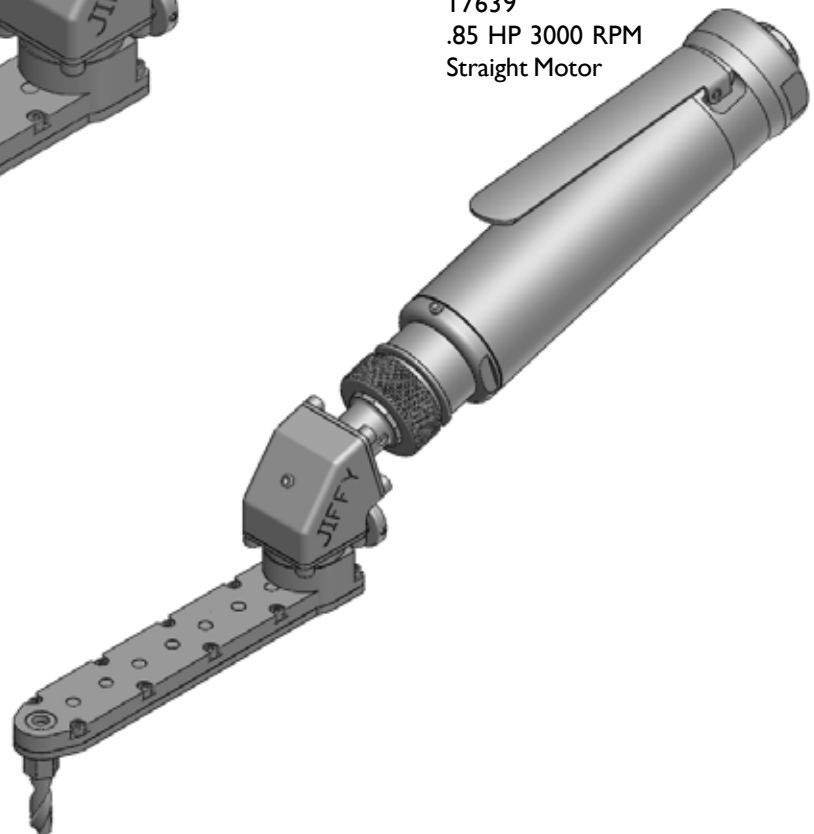

PHONE: 1 775 883 1072 FAX: 1 775 883 4857

	A	B	C	D	E	F	G	H	SERIES 3 17 DEGREE DRILL	
INCH	.425	2.23	3.1	.90	1.02	.327	1.68	1.10	MAXIMUM RECOMMENDED DRILL DIAMETER	.312 INCH
MM	10.79	56.6	78.7	22.8	25.9	8.3	42.6	27.9		7.92 mm



## SERIES 3 INDEXABLE 17 DEGREE DRILLS

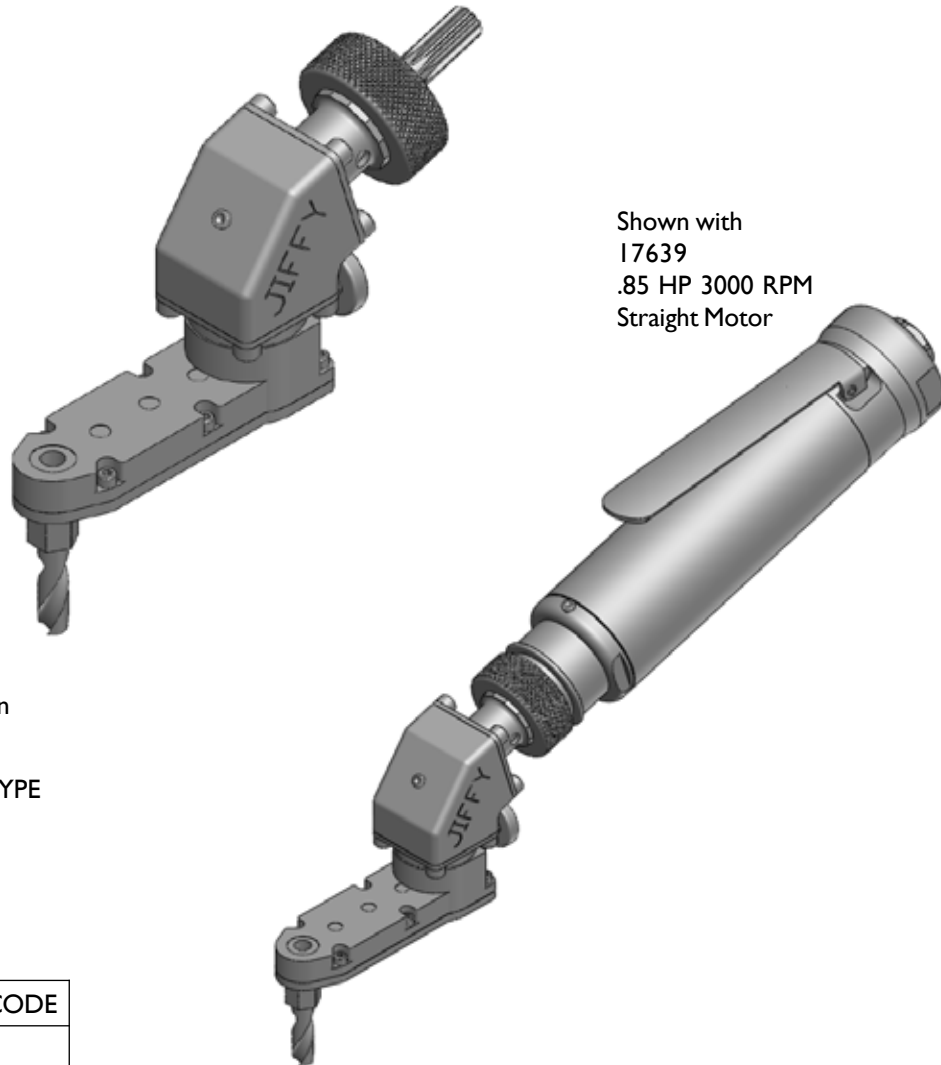
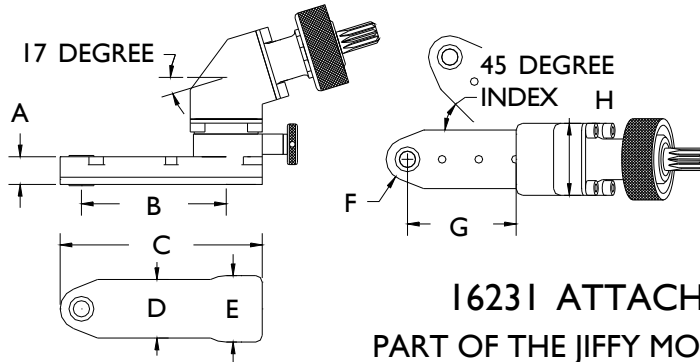

You must select an internal thread

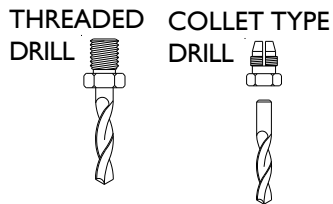

INTERNAL THREAD CODE	
1/4-28	A
10-32	C
9/32-40	E
5/16-24	F
7mm COLLET	D

PHONE: | 775 883 1072 FAX: | 775 883 4857

	A	B	C	D	E	F	G	H	SERIES 3 17 DEGREE DRILL	
INCH	.425	3.35	4.22	.90	1.02	.327	2.80	1.10	MAXIMUM RECOMMENDED	.312 INCH
MM	10.79	85	107.1	22.8	25.9	8.3	71.1	27.9	DRILL DIAMETER	7.92 mm



### SERIES 3 INDEXABLE 17 DEGREE DRILLS

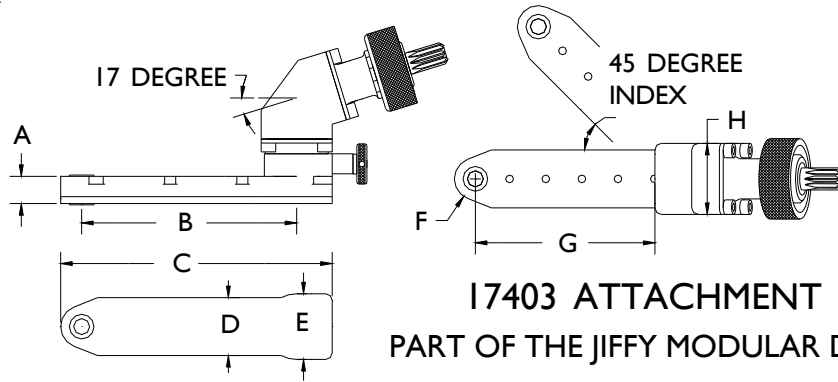

**I7403 ATTACHMENT ONLY**  
PART OF THE JIFFY MODULAR DRILL SYSTEM

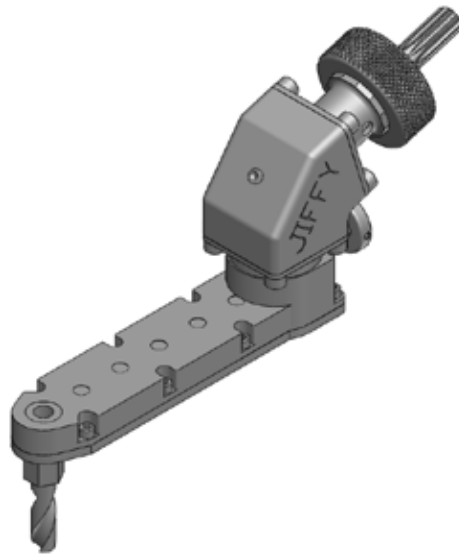

Shown with  
I7639  
.85 HP 3000 RPM  
Straight Motor

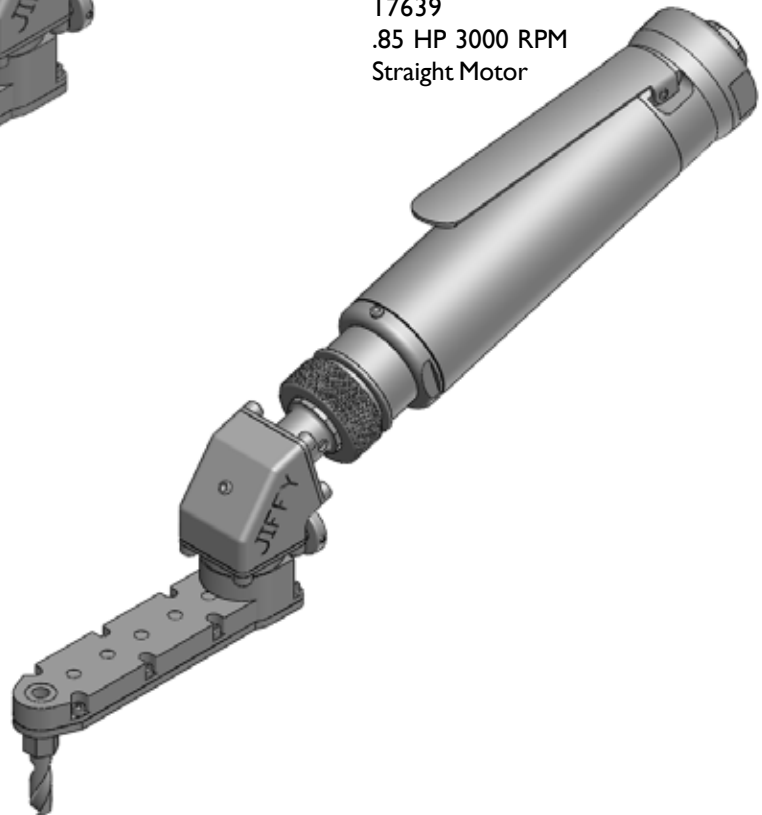

You must select an internal thread

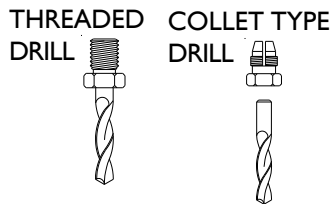

INTERNAL THREAD CODE	
1/4-28	A
10-32	C
9/32-40	E
5/16-24	F
7mm COLLET	D

PHONE: 1 775 883 1072 FAX: 1 775 883 4857

	A	B	C	D	E	F	G	H	SERIES 3 17 DEGREE DRILL	
INCH	.425	4.48	5.35	.90	1.02	.327	3.93	1.10	MAXIMUM RECOMMENDED	.312 INCH
MM	10.79	113.8	135.9	22.8	25.9	8.3	99.8	27.9	DRILL DIAMETER	7.92 mm



## SERIES 3 INDEXABLE 17 DEGREE DRILLS

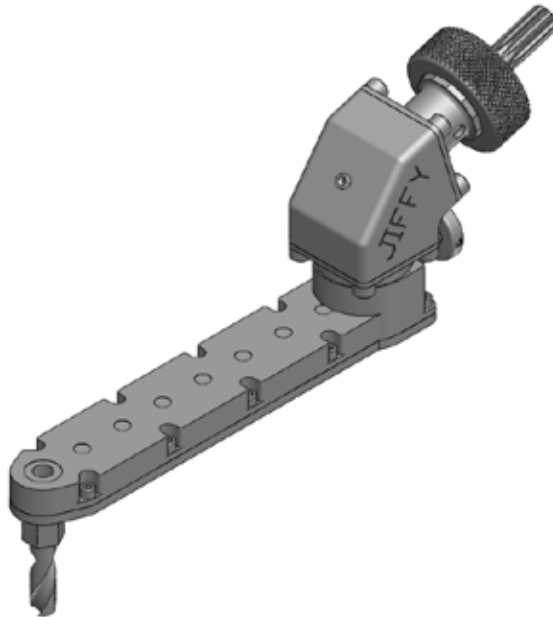
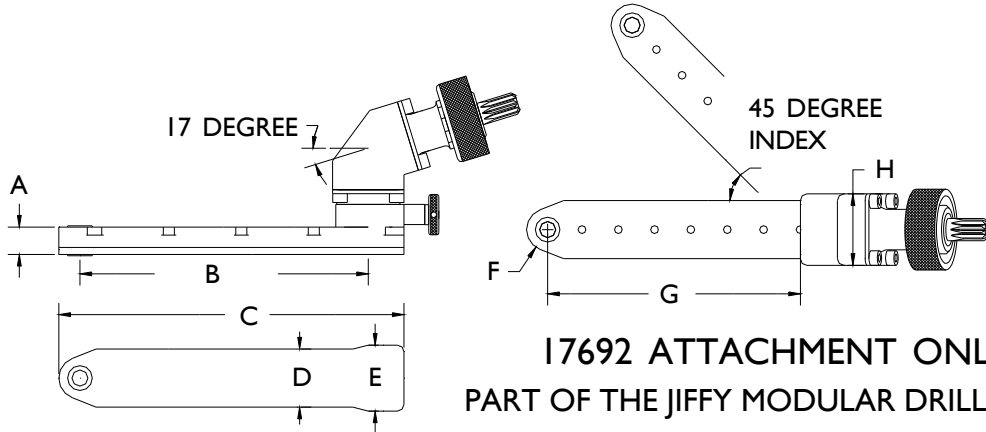

Shown with  
17639  
.85 HP 3000 RPM  
Straight Motor

You must select an  
internal thread

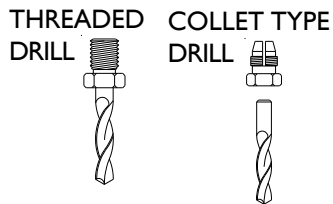

INTERNAL THREAD CODE	
1/4-28	A
10-32	C
9/32-40	E
5/16-24	F
7mm COLLET	D

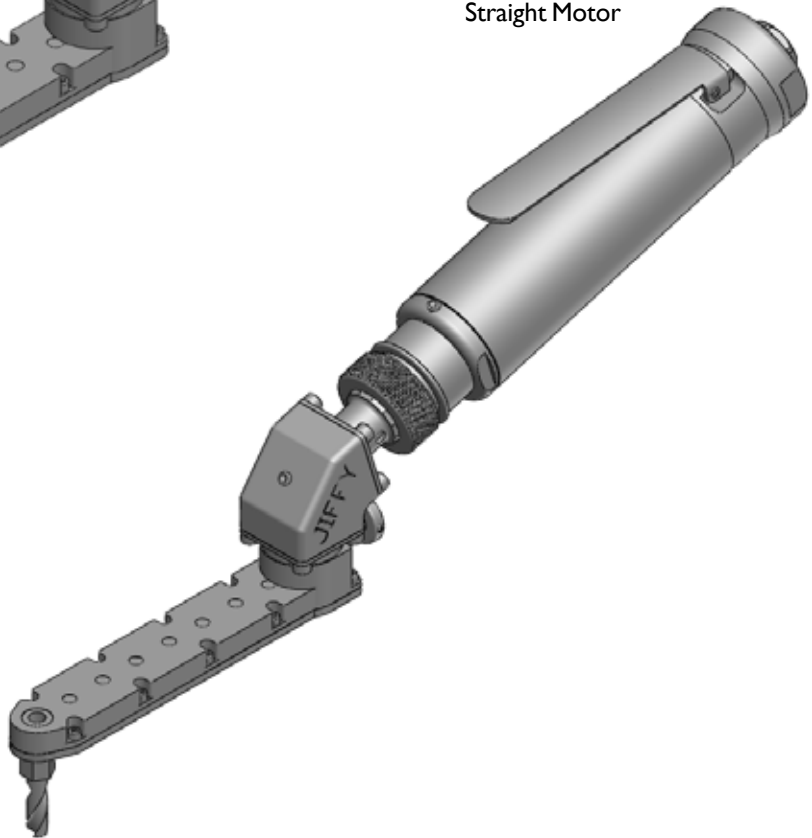

PHONE: 1 775 883 1072 FAX: 1 775 883 4857

	A	B	C	D	E	F	G	H	I	SERIES 3 17 DEGREE DRILL	
INCH	.350	3.35	4.22	.90	1.02	.327	2.80	1.10	2.124	MAXIMUM RECOMMENDED	.312 INCH
MM	8.89	85	107.1	22.8	25.9	8.3	71.1	27.9	53.94	DRILL DIAMETER	7.92 mm



## SERIES 3 17 DEGREE DRILLS

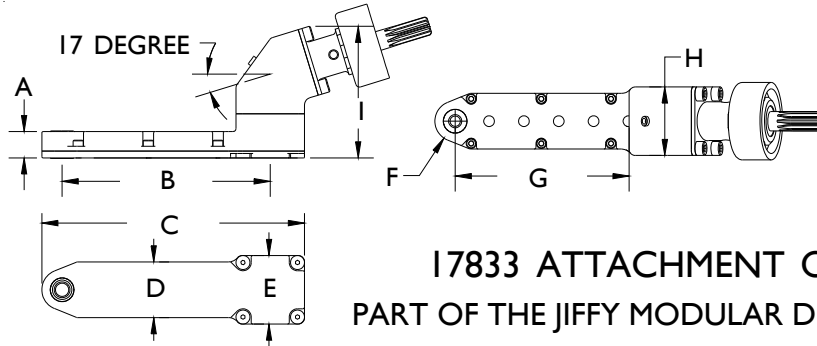

**17833 ATTACHMENT ONLY**  
PART OF THE JIFFY MODULAR DRILL SYSTEM

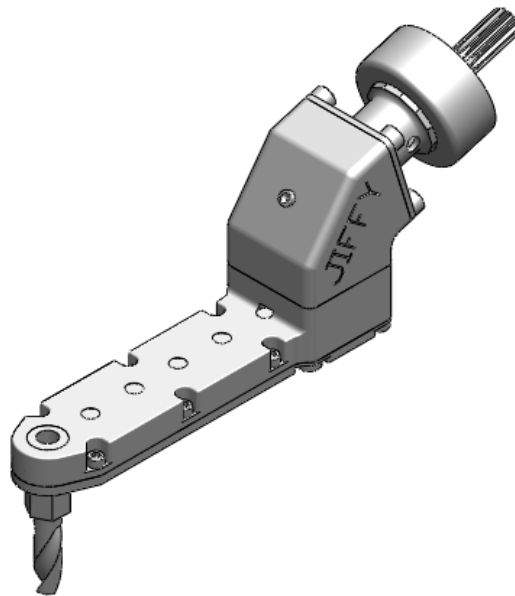

Shown with  
17639  
.85 HP 3000 RPM  
Straight Motor

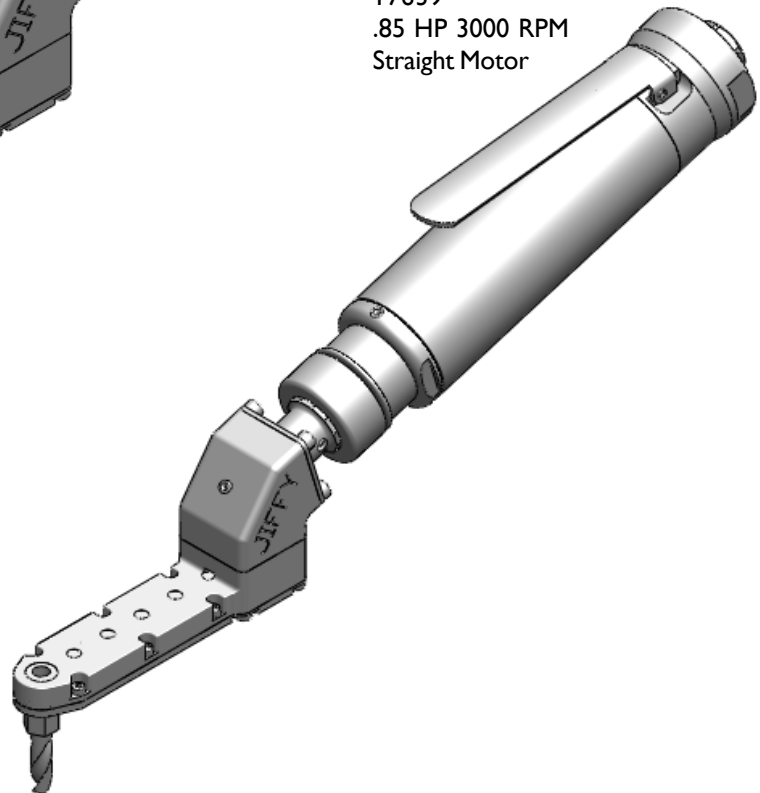

You must select an  
internal thread

THREADED  
DRILL



COLLET TYPE  
DRILL



INTERNAL THREAD CODE	
1/4-28	A
10-32	C
9/32-40	E
5/16-24	F
7mm COLLET	D



	A	B	C	D	E	F	G	H	SERIES 4 17 DEGREE DRILL	
INCH	.500	3.208	4.211	1.106	.450	2.655	1.106	2.303	MAXIMUM RECOMMENDED DRILL DIAMETER	.375 INCH
MM	12.7	81.483	106.95	28.092	11.43	67.437	28.092	58.496		9.52 mm



## SERIES 4 17 DEGREE DRILLS

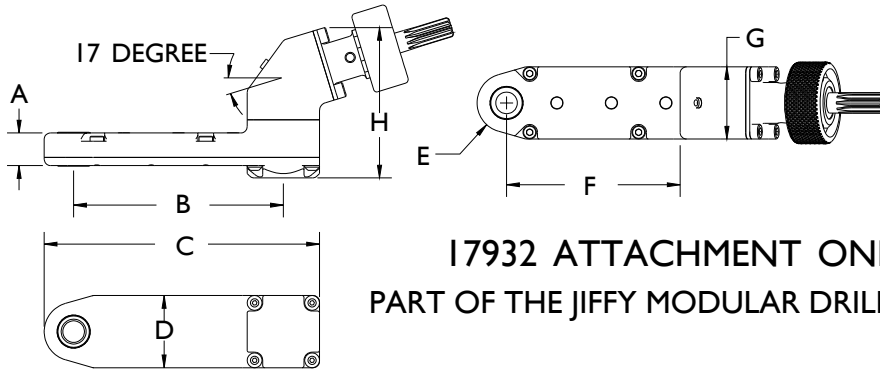

17932 ATTACHMENT ONLY  
PART OF THE JIFFY MODULAR DRILL SYSTEM



Shown with  
17639  
.85 HP 3000 RPM  
Straight Motor

You must select an  
internal thread

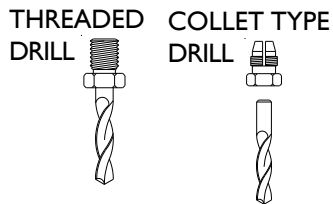

INTERNAL THREAD CODE	
1/4-28	A
9/32-40	E
5/16-24	F
3/8-24	Z
7mm COLLET	D
3/8-24 MALE	Y

	A	B	0-1/4 CHUCK	
INCH	2.892	1.174	MAXIMUM RECOMMENDED	.250
MM	73.45	29.81	DRILL DIAMETER	6.35 mm



0-1/4 CHUCK ATTACHMENT  
I5053 ATTACHMENT ONLY

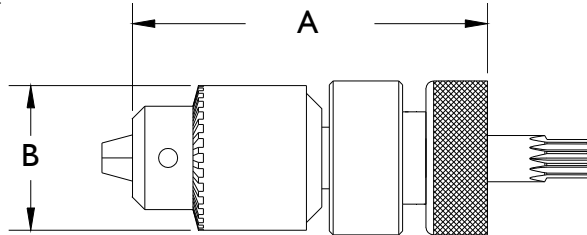

CHUCK KEY AND LEASH INCLUDED

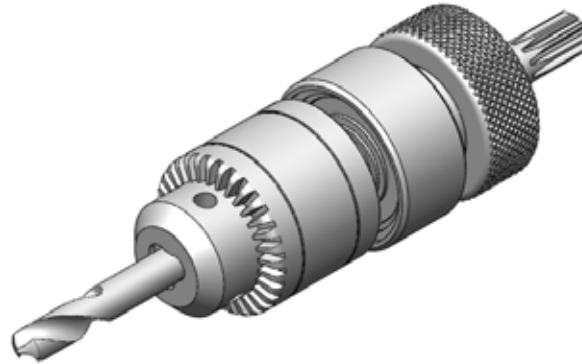

Shown with  
I7750  
.85 HP 3000 RPM  
Offset Motor

PHONE: | 775 883 1072 FAX: | 775 883 4857

	A	B	0-3/8 CHUCK	
INCH	3.515	1.670	MAXIMUM RECOMMENDED	.375
MM	89.28	42.41	DRILL DIAMETER	9.52 mm



0-3/8 CHUCK ATTACHMENT  
I5037 ATTACHMENT ONLY

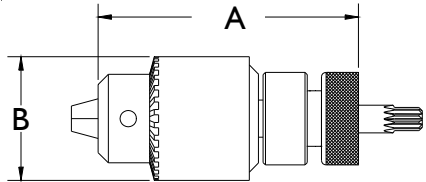

CHUCK KEY AND LEASH INCLUDED

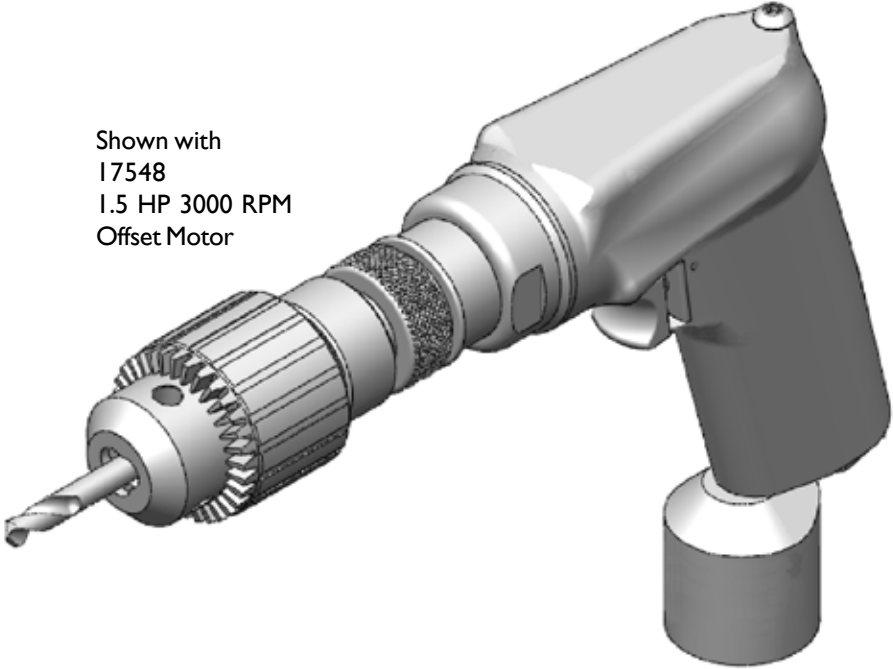
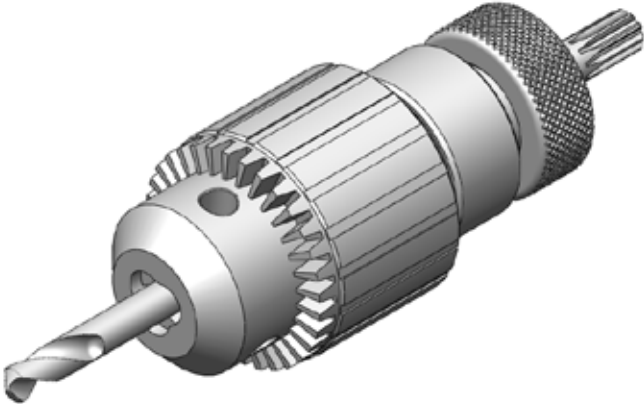

Shown with  
I7548  
1.5 HP 3000 RPM  
Offset Motor

PHONE: 1 775 883 1072 FAX: 1 775 883 4857

	A	B	5/64 - 1/2 CHUCK	
INCH	3.765	1.781	MAXIMUM RECOMMENDED	.500
MM	95.63	45.23	DRILL DIAMETER	12.7 mm



5/64 - 1/2 CHUCK ATTACHMENT  
I6490 ATTACHMENT ONLY

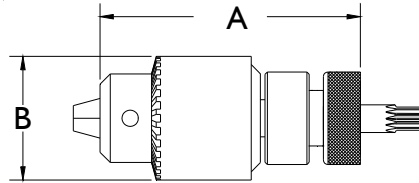

CHUCK KEY AND LEASH INCLUDED

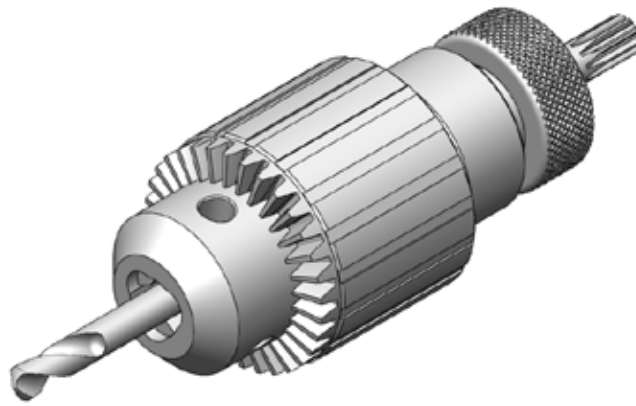

Shown with  
I7548  
1.5 HP 3000 RPM  
Offset Motor

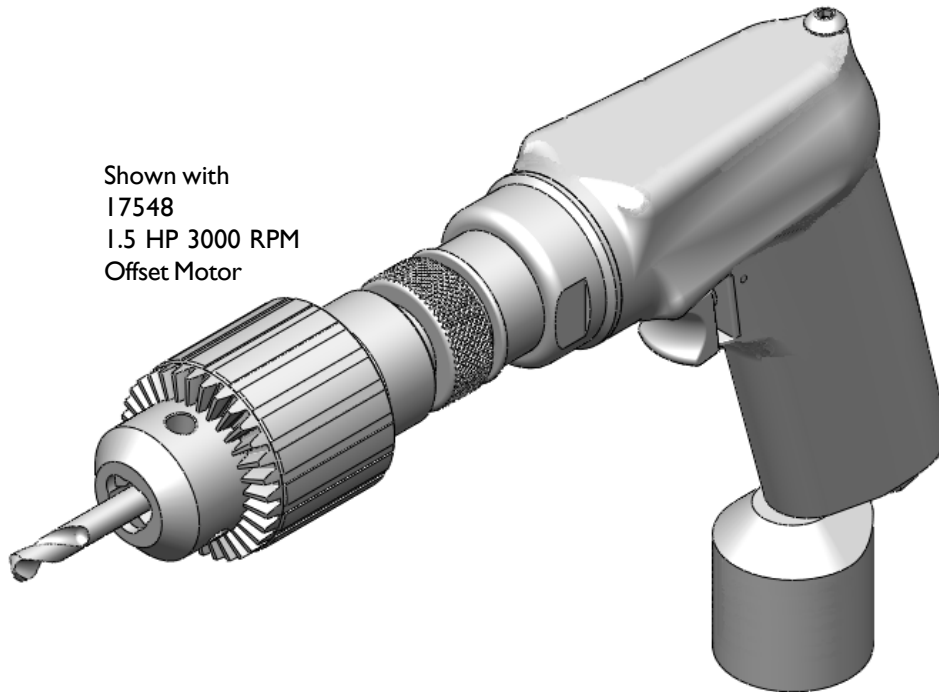

PHONE: 1 775 883 1072 FAX: 1 775 883 4857

# JIFFY MODULAR DRILL (JMD) 1.5 H.P. OFFSET HANDLE

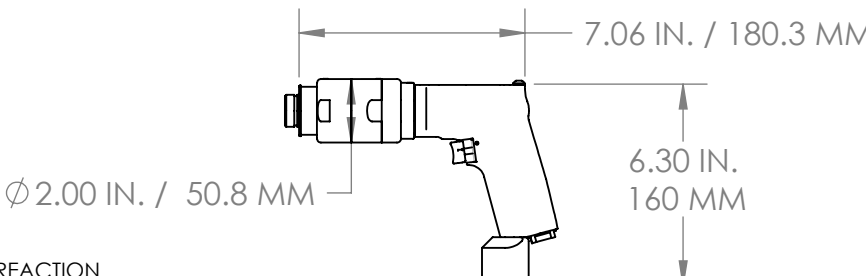
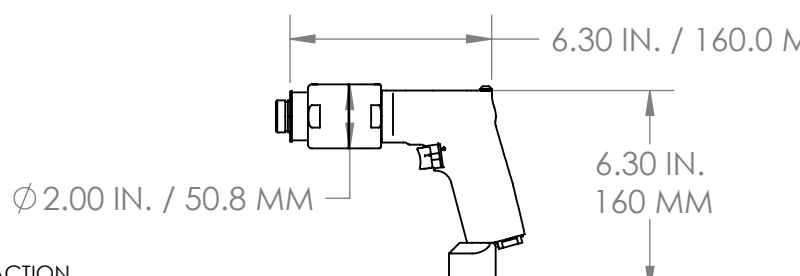
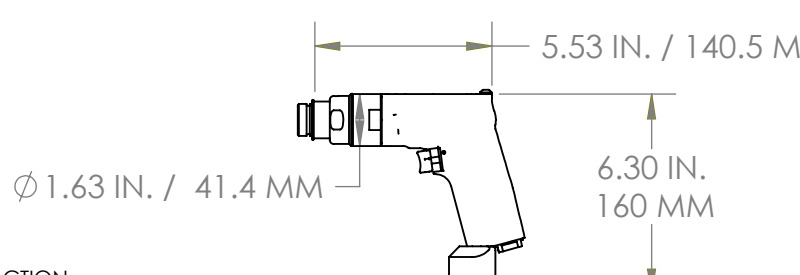
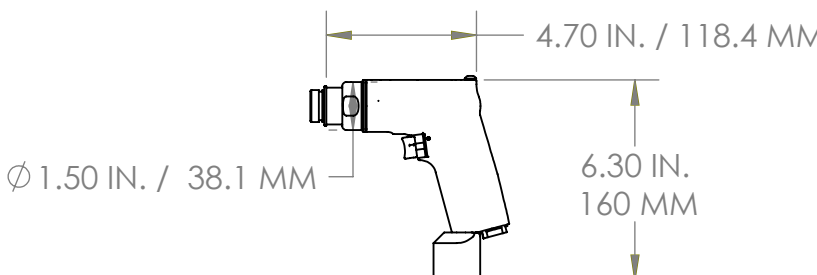
RPM	ORDER NUMBER	WEIGHT
250	20421	3.48 LB / 1.58 KG
 <p style="text-align: center;">20466 TORQUE REACTION HANDLE REQUIRED</p>		
500	20992	3.12 LB / 1.42 KG
 <p style="text-align: center;">20466 TORQUE REACTION HANDLE REQUIRED</p>		
2000	17547	2.47 LB / 1.12 KG
 <p style="text-align: center;">17908 TORQUE REACTION HANDLE AVAILABLE</p>		
3000	17548	2.20 LB / 1.0 KG
6000	17549	2.20 LB / 1.0 KG
 <p style="text-align: center;">17908 TORQUE REACTION HANDLE AVAILABLE</p>		

# JIFFY MODULAR DRILL (JMD) 1.5 H.P. STRAIGHT HANDLE



RPM	ORDER NUMBER	WEIGHT
250	20419	3.68LB / 1.67 KG
20466 TORQUE REACTION HANDLE REQUIRED 		
500	20991	3.32 LB / 1.50 KG
20466 TORQUE REACTION HANDLE REQUIRED 		
2000	17521	2.63 LB / 1.20 KG
17908 TORQUE REACTION HANDLE AVAILABLE 		
3000	17474	2.2 LB / 1.0 KG
6000	17300	2.2 LB / 1.0 KG
17908 TORQUE REACTION HANDLE AVAILABLE 		

PHONE: I 775 883 1072 FAX: I 775 883 4857

# JIFFY MODULAR DRILL (JMD) .90 H.P. REVERSIBLE OFFSET HANDLE



RPM	DRIVE	ORDER NUMBER	WEIGHT
250	10-T SPLINE	21541	3.42 LB / 1.55 KG
500	10-T SPLINE	21516	3.32 LB / 1.5 KG
1000	10-T SPLINE	19337	2.6 LB / 1.2 KG
3000	10-T SPLINE	19339	2.3 LB / 1.1 KG
5000	10-T SPLINE	19340	2.3 LB / 1.1 KG

PHONE: | 775 883 1072 FAX: | 775 883 4857

# JIFFY MODULAR DRILL (JMD) .90 H.P. REVERSIBLE STRAIGHT HANDLE



RPM	DRIVE	ORDER NUMBER	WEIGHT
250	10-T SPLINE	21540	3.45 LB / 1.56 KG
500	10-T SPLINE	21515	3.23 LB / 1.46 KG
1000	10-T SPLINE	19352	2.80 LB / 1.27 KG
3000	10-T SPLINE	19354	2.50 LB / 1.13 KG
5000	10-T SPLINE	19355	2.50 LB / 1.13 KG

PHONE: | 775 883 1072 FAX: | 775 883 4857



# JIFFY MODULAR DRILL (JMD) .85 H.P. OFFSET HANDLE



RPM	ORDER NUMBER	WEIGHT
250	18091	1.94 LB / .88 KG
500	17847	1.64 LB / .74 KG
1000	17743	1.47 LB / .67 KG
2000	17848	1.47 LB / .67 KG
3000	17750	1.35 LB / .61 KG
6000	17849	1.35 LB / .61 KG

PHONE: | 775 883 1072 FAX: | 775 883 4857

# JIFFY MODULAR DRILL (JMD) .85 H.P. REVERSE-RUNNING OFFSET HANDLE



RPM	ORDER NUMBER	WEIGHT
250	20014	1.94 LB / .88 KG
500	17858	1.64 LB / .74 KG
1000	17859	1.47 LB / .67 KG
2000	17860	1.47 LB / .67 KG
3000	17861	1.35 LB / .61 KG
6000	17862	1.35 LB / .61 KG

PHONE: I 775 883 1072 FAX: I 775 883 4857

JIFFY MODULAR DRILL (JMD)  
 .85 H.P. STRAIGHT HANDLE



RPM	ORDER NUMBER	WEIGHT
250	18092	2.1 LB / .95 KG
500	17657	1.6 LB / .73 KG
1000	17684	1.5 LB / .68 KG
2000	17698	1.7 LB / .77 KG
3000	17639	1.3 LB / .59 KG
6000	17662	1.3 LB / .59 KG

PHONE: I 775 883 1072 FAX: I 775 883 4857

# JIFFY MODULAR DRILL (JMD) .85 H.P. REVERSE RUNNING STRAIGHT HANDLE



RPM	ORDER NUMBER	WEIGHT
250	18115	2.1 LB / .95 KG
500	17853	1.6 LB / .73 KG
1000	17854	1.5 LB / .68 KG
2000	17855	1.7 LB / .77 KG
3000	17856	1.3 LB / .59 KG
6000	17857	1.3 LB / .59 KG

PHONE: I 775 883 1072 FAX: I 775 883 4857

JIFFY MODULAR DRILL  
 .3 H.P. MOTOR COMPLETE  
 OFFSET HANDLE - DOWN EXHAUST



RPM	ORDER NUMBER	WEIGHT
250	22816	1.55 LB / .70 KG
500	22817	1.55 LB / .70 KG
750	22818	1.55 LB / .70 KG
1000	22819	1.55 LB / .70 KG
1500	22820	1.55 LB / .70 KG

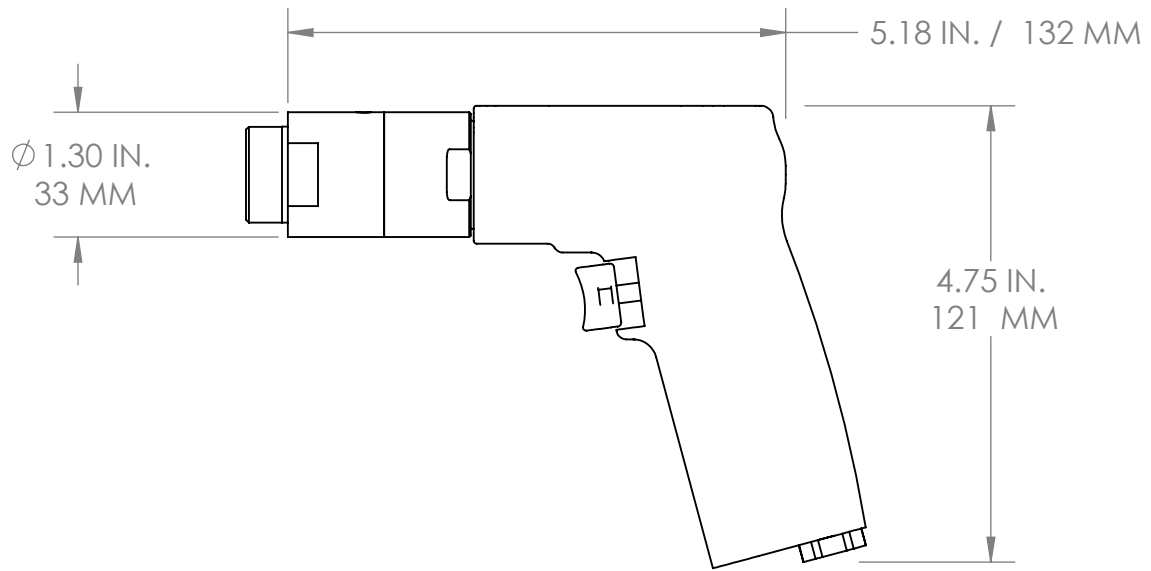

2800	22821	1.2 LB / .55 KG
4500	22822	1.2 LB / .55 KG

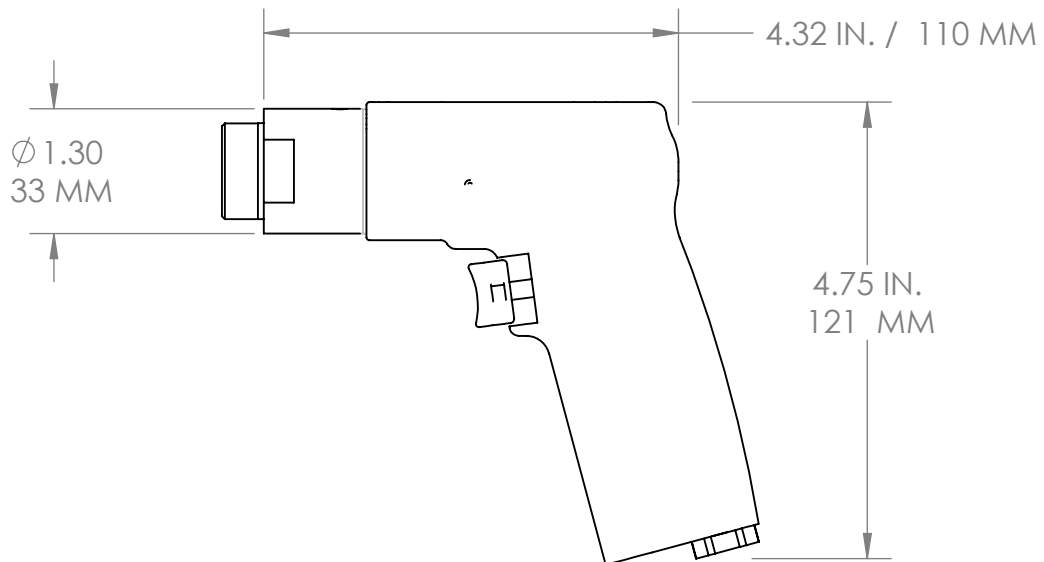

PHONE: | 775 883 1072 FAX: | 775 883 4857

JIFFY MODULAR DRILL  
 .3 H.P. MOTOR COMPLETE  
 OFFSET HANDLE - DOWN EXHAUST  
REVERSE - RUNNING



RPM	ORDER NUMBER	WEIGHT
250	22825	1.55 LB / .70 KG
500	22826	1.55 LB / .70 KG
750	22827	1.55 LB / .70 KG
1000	22828	1.55 LB / .70 KG
1500	22829	1.55 LB / .70 KG

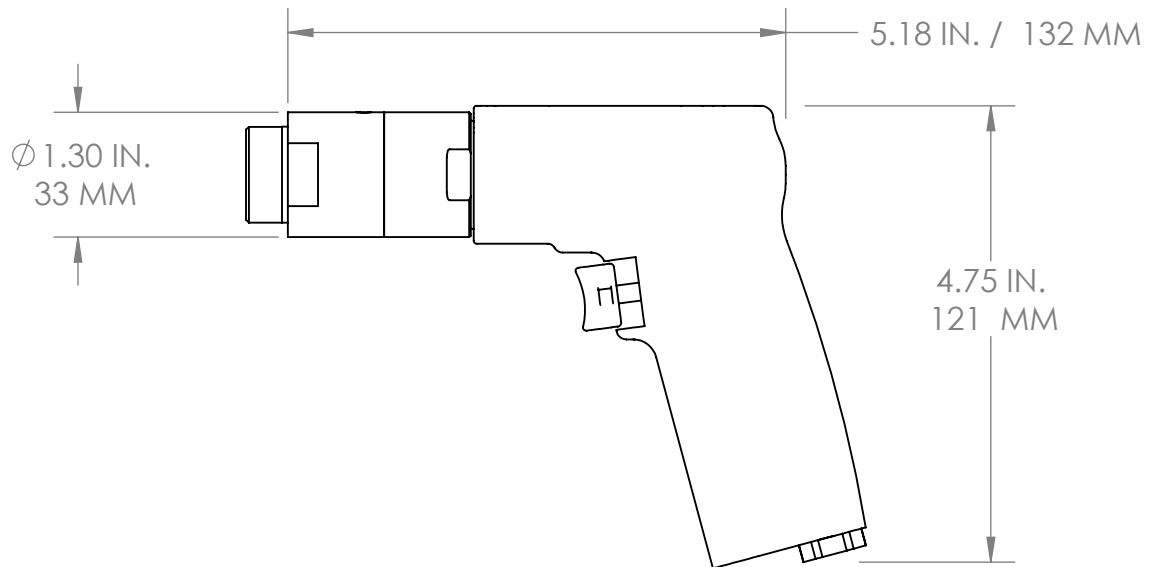

2800	22830	1.2 LB / .55 KG
4500	22831	1.2 LB / .55 KG

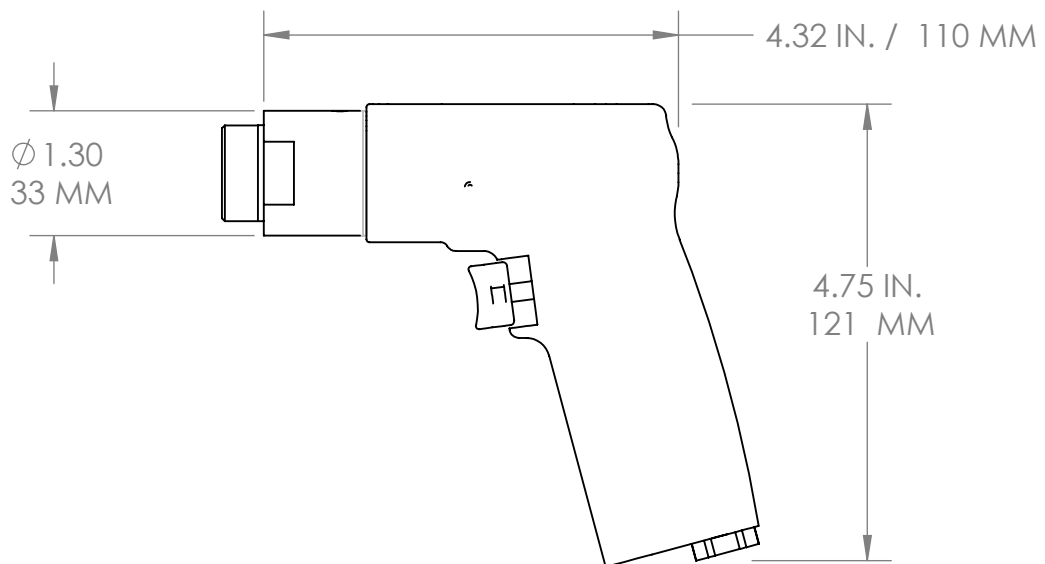

PHONE: | 775 883 1072 FAX: | 775 883 4857



## JIFFY MODULAR DRILL (JMD) SD SERIES .30 H.P. STRAIGHT HANDLE

RPM	ORDER NUMBER	WEIGHT
250	15420S	1.50 LB / .68 KG
500	14812S	1.50 LB / .68 KG
750	14974S	1.50 LB / .68 KG
1000	14975S	1.50 LB / .68 KG
1500	14976S	1.50 LB / .68 KG

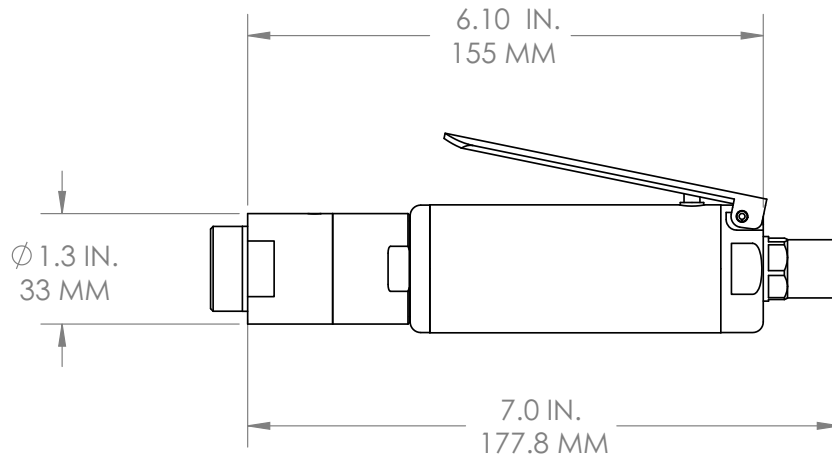

2800	14811S	1.20 LB / .54 KG
4500	17206S	1.20 LB / .54 KG

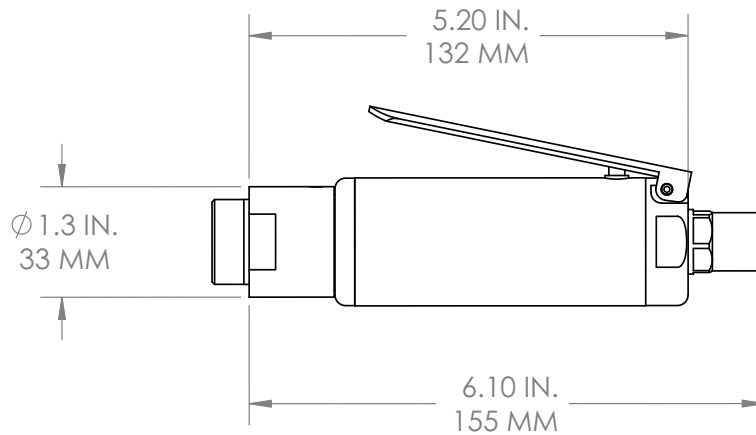

PHONE: I 775 883 1072 FAX: I 775 883 4857



**JIFFY MODULAR DRILL (JMD)  
SD SERIES .30 H.P. STRAIGHT HANDLE  
REVERSE RUNNING**

RPM	ORDER NUMBER	WEIGHT
250	15420SK	1.50 LB / .68 KG
500	14812SK	1.50 LB / .68 KG
750	14974SK	1.50 LB / .68 KG
1000	14975SK	1.50 LB / .68 KG
1500	14976SK	1.50 LB / .68 KG

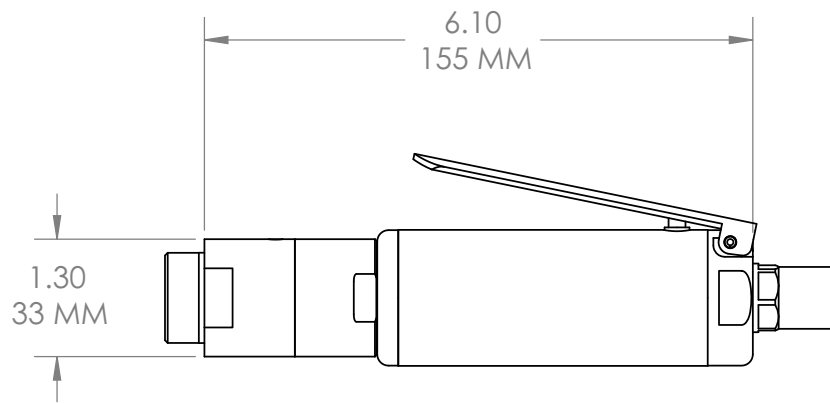

2800	14811SK	1.20 LB / .54 KG
4500	17206SK	1.20 LB / .54 KG

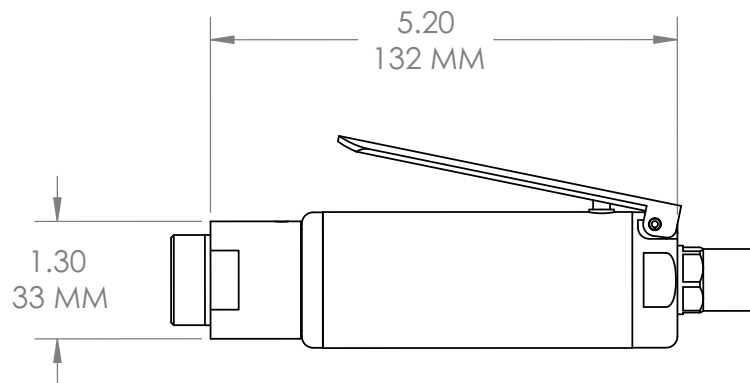

PHONE: I 775 883 1072 FAX: I 775 883 4857





**JIFFY MODULAR DRILL (JMD)  
RD2 SERIES .40 H.P. OFFSET HANDLE  
REVERSIBLE MOTOR**

RPM	ORDER NUMBER	WEIGHT
250	10437	2.97 LB / 1.35 KG
450	10438	2.86 LB / 1.30 KG
1000	10440	2.86 LB / 1.30 KG
2000	10441	2.55 LB / 1.16 KG
2700	10442	2.55 LB / 1.16 KG
3500	14240	2.55 LB / 1.16 KG

PHONE: I 775 883 1072 FAX: I 775 883 4857



# JIFFY MODULAR DRILL (JMD) SRD2 SERIES .40 H.P. STRAIGHT HANDLE REVERSIBLE MOTOR

RPM	ORDER NUMBER	WEIGHT
250	16267	2.5 LB / 1.2 KG

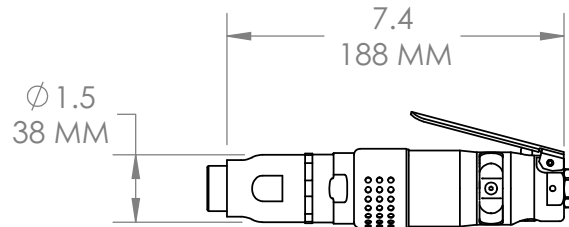

450	16181	2.3 LB / 1.1 KG
1000	16182	2.3 LB / 1.1 KG

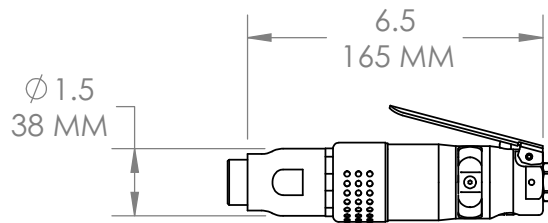

2000	16183	2.0 LB / 0.9 KG
2700	16184	2.0 LB / 0.9 KG
3500	17402	2.0 LB / 0.9 KG

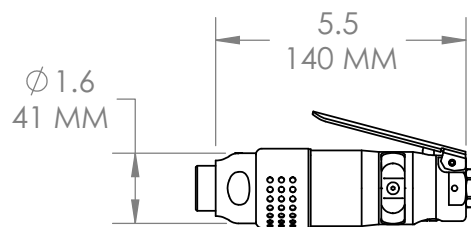

PHONE: I 775 883 1072 FAX: I 775 883 4857

# JIFFY MODULAR DRILL SAFETY LEVER OPTION



Add -I to the drill motor number to add the safety lever option

## .30 HP MOTORS

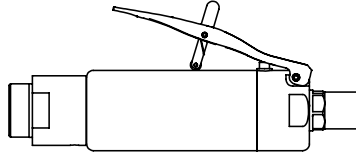

EXAMPLE: A 2800 RPM .30 HP motor number 14811 with the safety lever option would become 14811-I

## .85 HP MOTORS

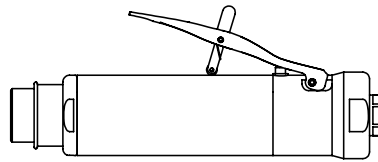

## .90 HP REVERSIBLE MOTORS

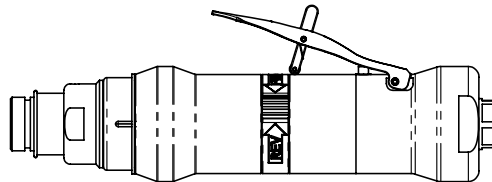

## 1.5 HP MOTORS

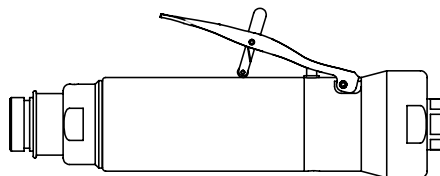

PHONE: 1 775 883 1072 FAX: 1 775 883 4857

# LTD SERIES 1

## ALL BEARING L TYPE DRILLS

### ATTACHMENTS ONLY

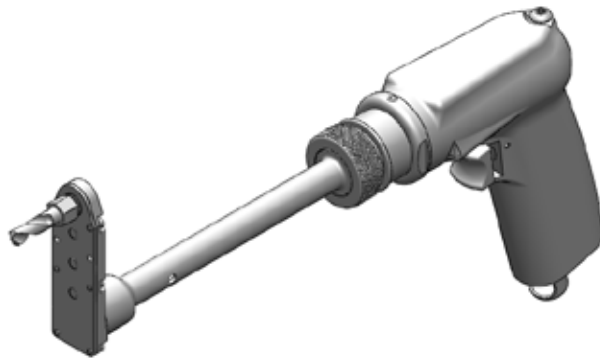

Shown with I7750  
.85 HP 3000 RPM  
offset motor

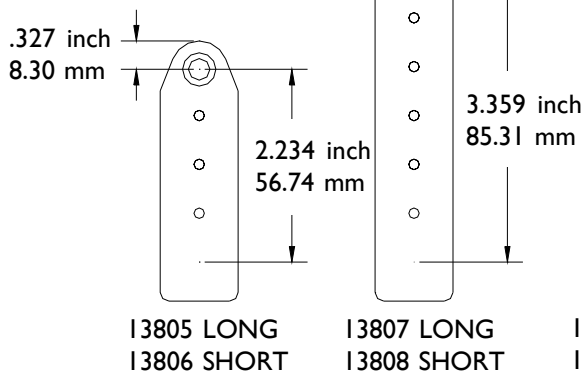
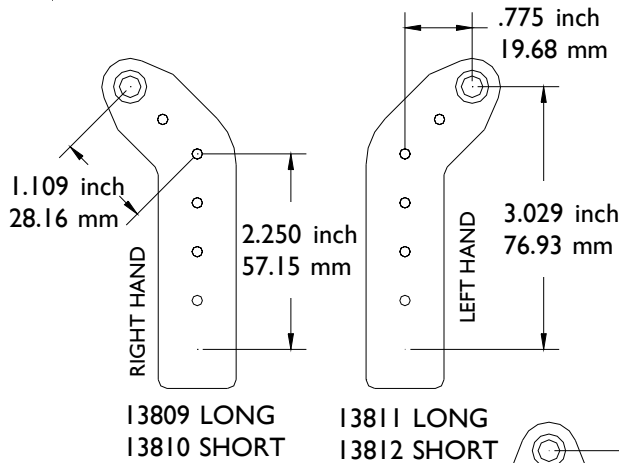
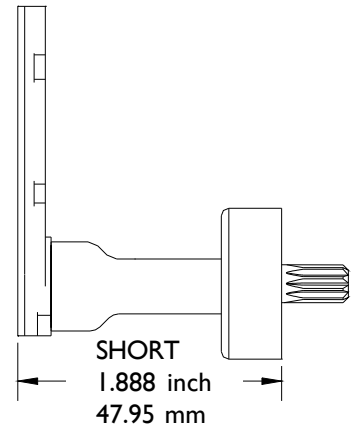
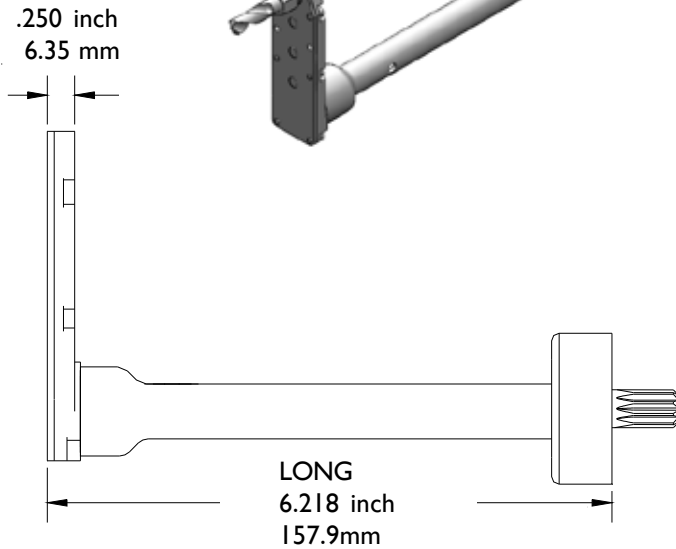

You must select an  
internal thread

THREADED  
DRILL



COLLET TYPE  
DRILL

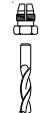

INTERNAL THREAD CODE	
1/4-28	A
10-32	C
9/32-40	E
5/16-24	F
7mm COLLET	D

PHONE: 775 883 1072 FAX: 775 883 4857

# LTD SERIES 2

## ALL BEARING L TYPE DRILLS

### ATTACHMENTS ONLY

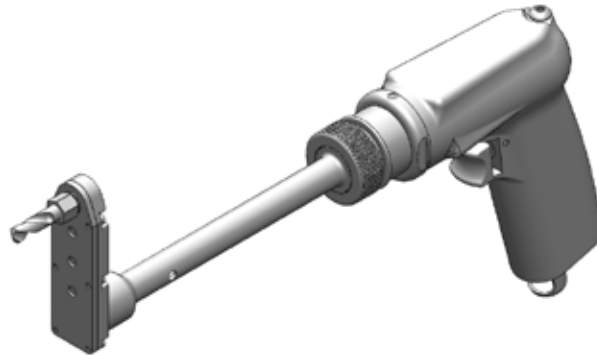

Shown with I7750  
.85 HP 3000 RPM  
offset motor

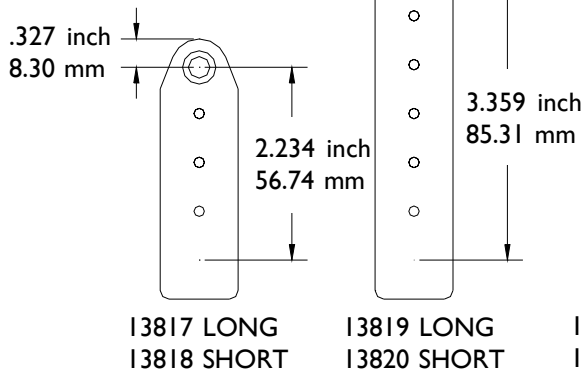
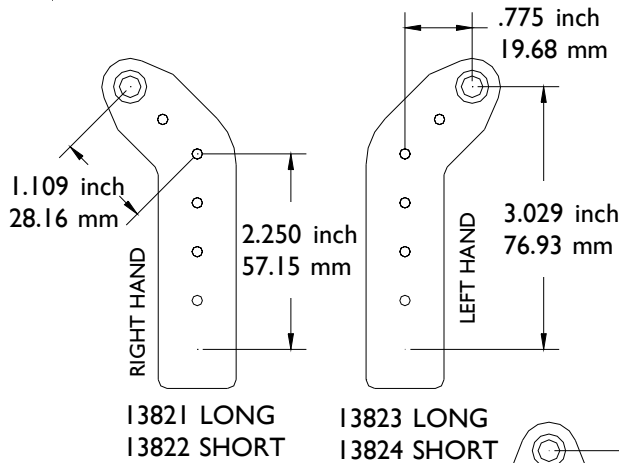
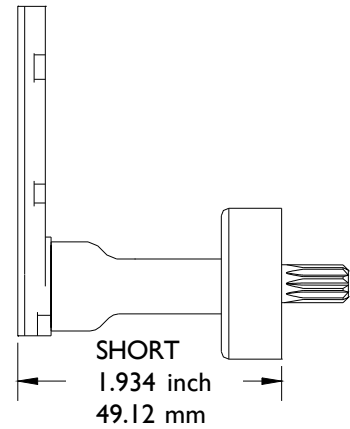
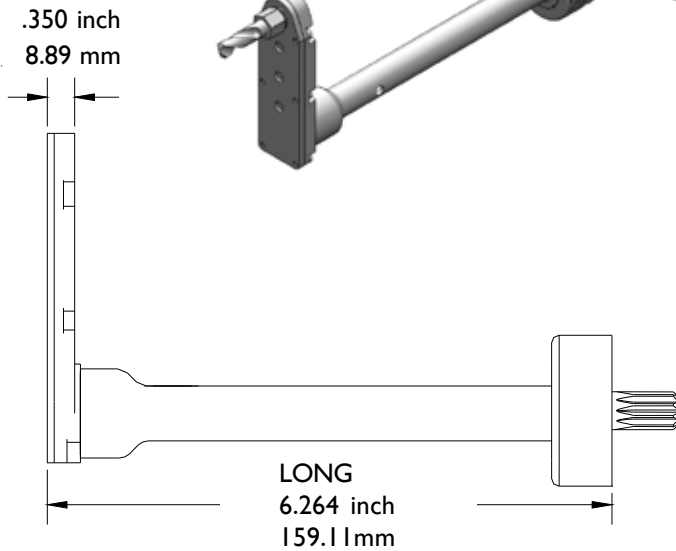

You must select an  
internal thread

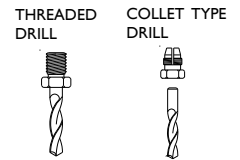

INTERNAL THREAD CODE	
1/4-28	A
10-32	C
9/32-40	E
5/16-24	F
7mm COLLET	D

PHONE: 775 883 1072 FAX: 775 883 4857

# LTD SERIES 3

## ALL BEARING L TYPE DRILLS

### ATTACHMENTS ONLY

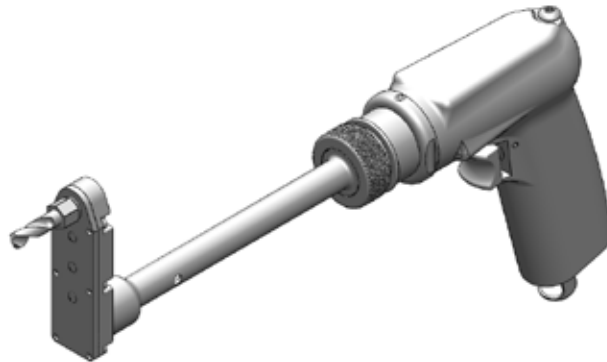

Shown with I7750  
.85 HP 3000 RPM  
offset motor

.425 inch  
10.79 mm

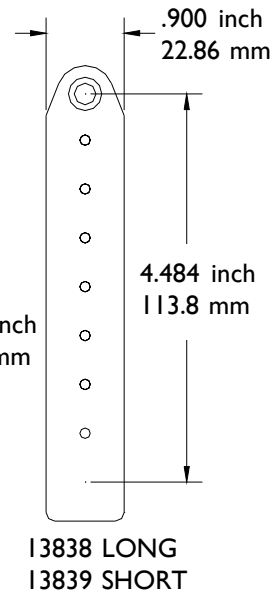
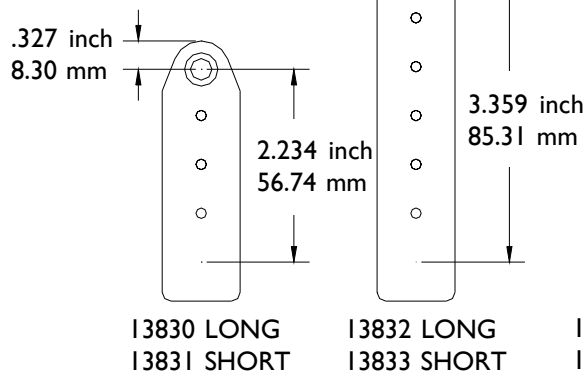
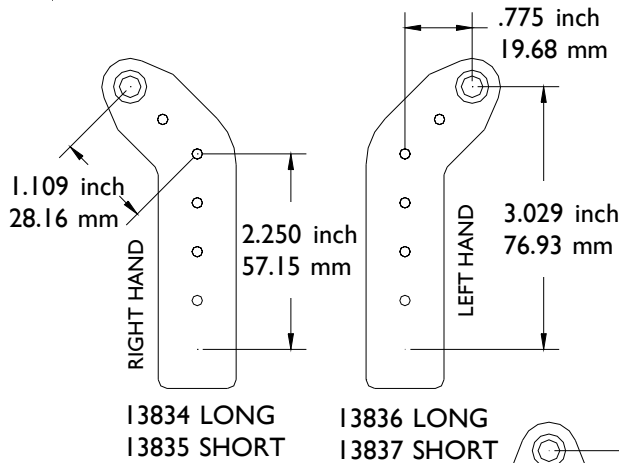
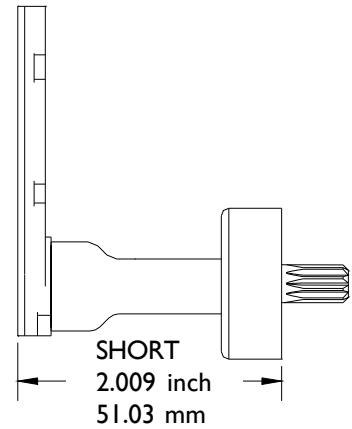
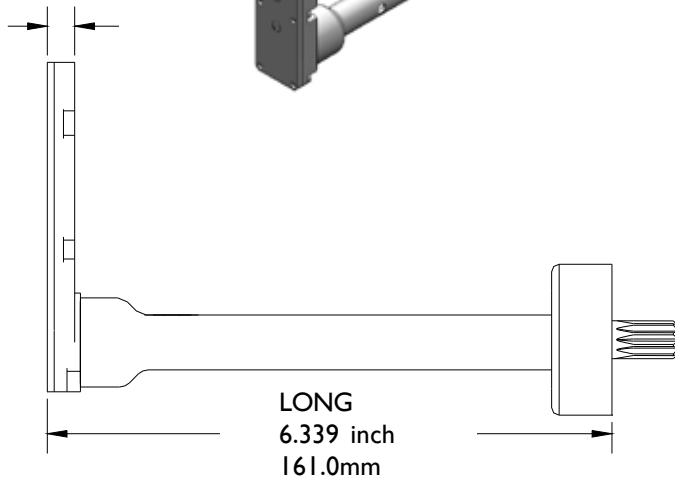

You must select an  
internal thread

THREADED  
DRILL



COLLET TYPE  
DRILL

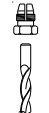

INTERNAL THREAD CODE	
1/4-28	A
10-32	C
9/32-40	E
5/16-24	F
7mm COLLET	D

PHONE: 775 883 1072 FAX: 775 883 4857

# LTD SERIES 4

## ALL BEARING L TYPE DRILLS

### ATTACHMENTS ONLY



Shown with I7750  
.85 HP 3000 RPM  
offset motor

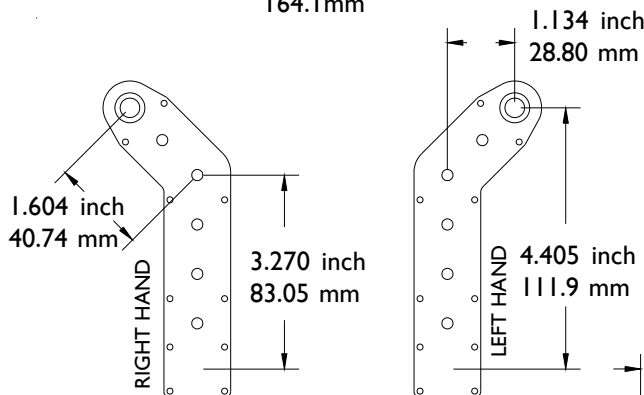
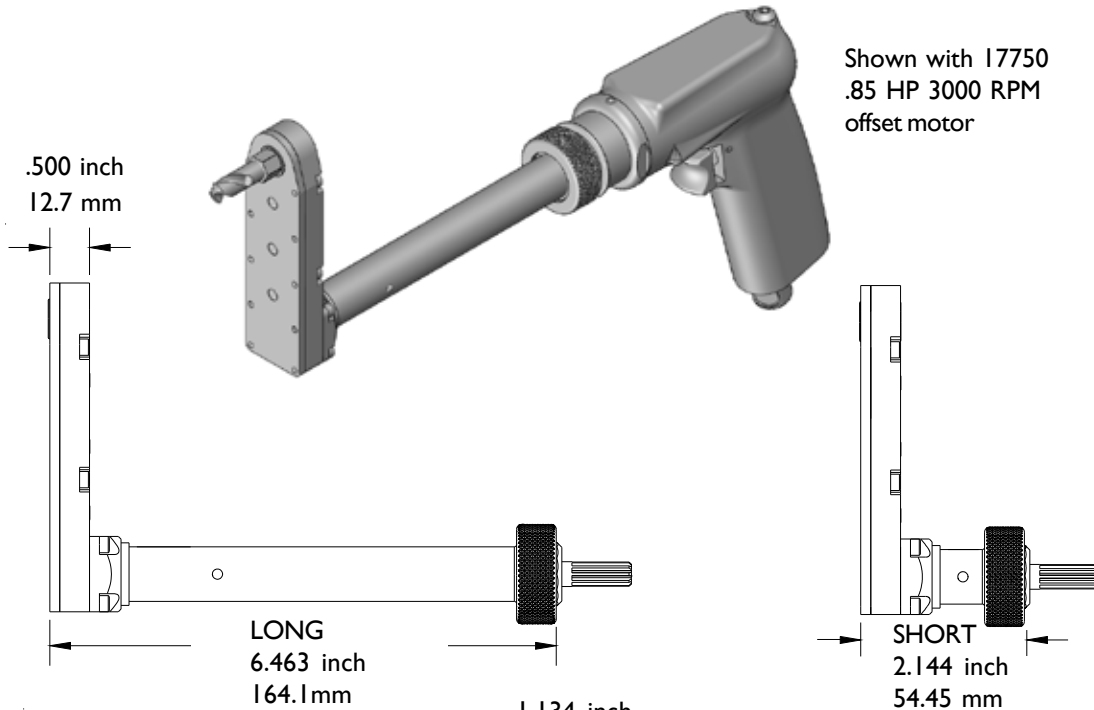

17884 LONG  
17885 SHORT

17886 LONG  
17887 SHORT

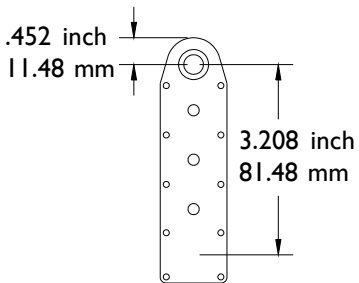

17726 LONG  
17768 SHORT

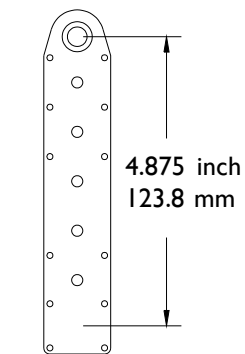

17736 LONG  
17769 SHORT

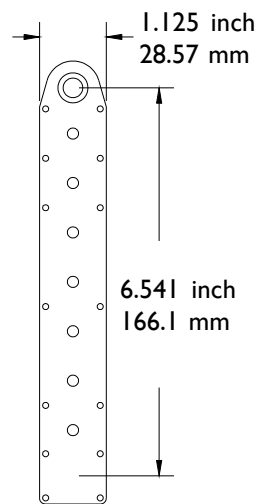

17737 LONG  
17770 SHORT

You must select an  
internal thread

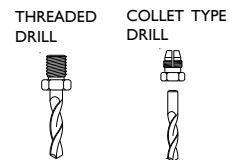

INTERNAL THREAD CODE	
1/4-28	A
9/32-40	E
5/16-24	F
3/8-24	Z
7mm COLLET	D
3/8-24 MALE	Y

PHONE: 775 883 1072 FAX: 775 883 4857



THIN LINE L DRILLS  
JMD  
10-32 THREAD

The "THIN LINE" L type drills are available for special applications where our standard L type drills will not fit. While we have made them as durable as possible in the space that is available, they should only be considered for areas that can't be reached with our standard attachments.

Do not operate at over 3000 RPM

Special application attachments with limited durability.

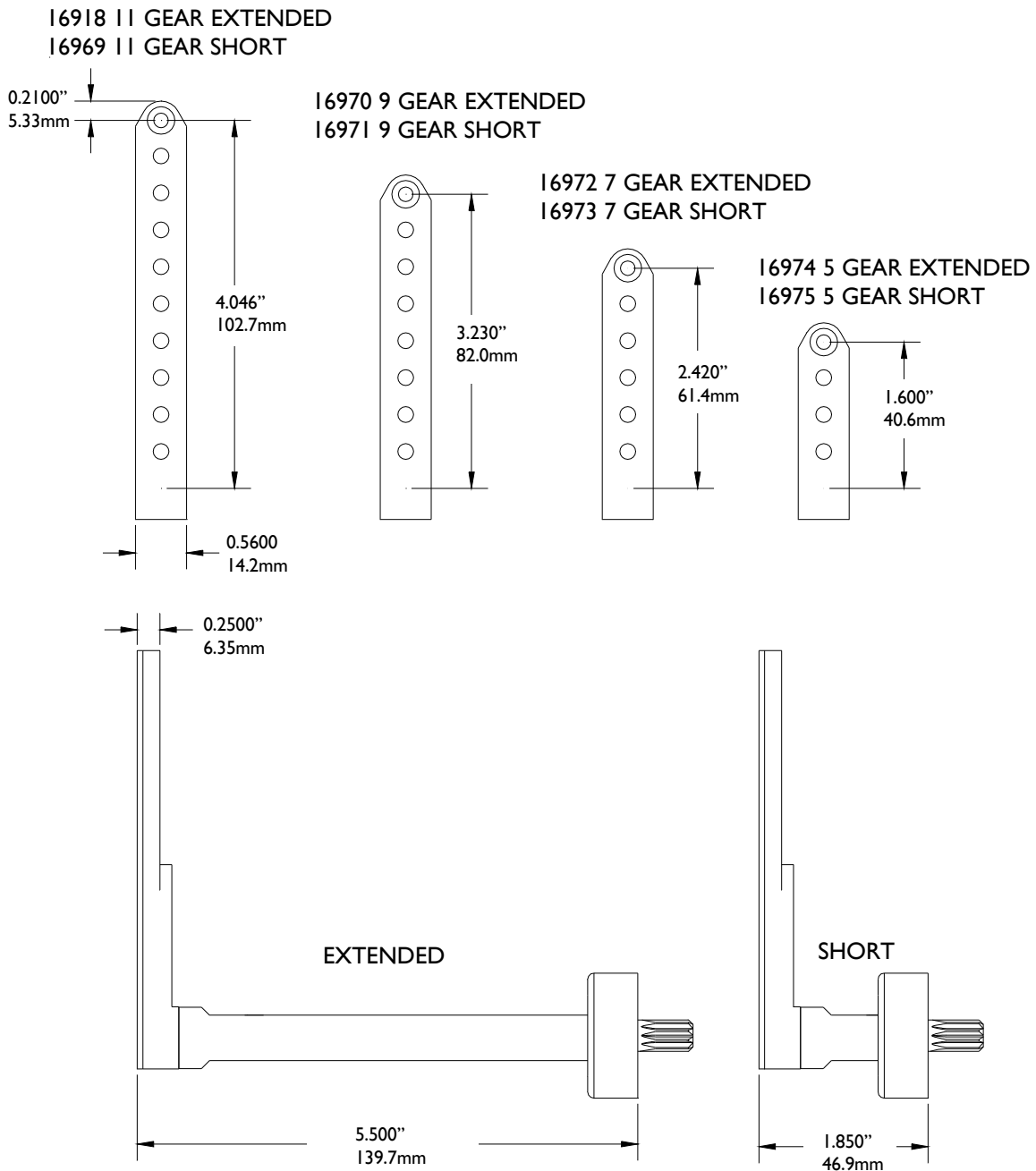

PHONE: 775 883 1072 FAX: 775 883 4857



# FAD SERIES 1

## ALL BEARING FLAT ANGLE DRILLS



FOR .250 or 7 mm CHUCKS  
AND BALL LOCK ADAPTERS

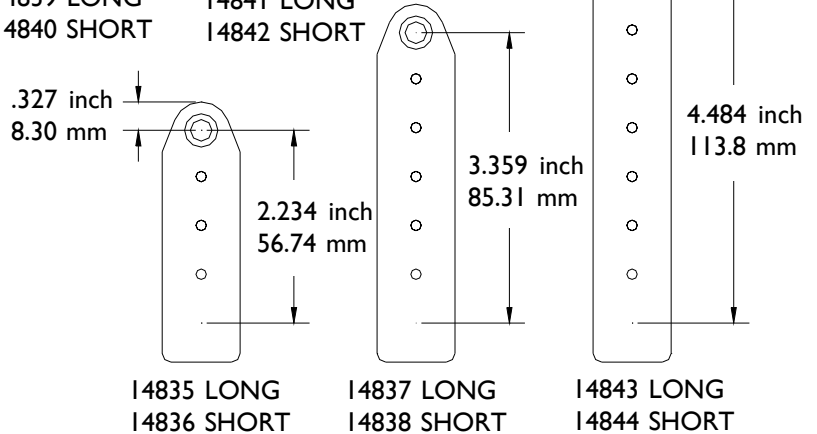
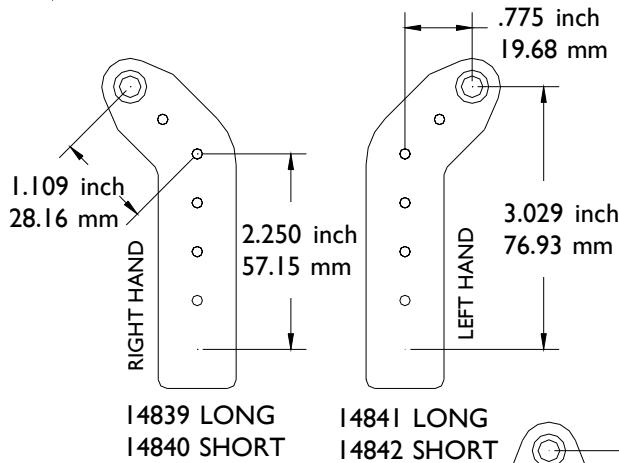
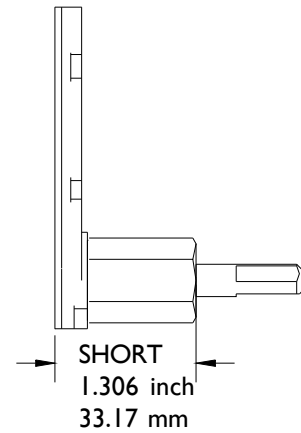
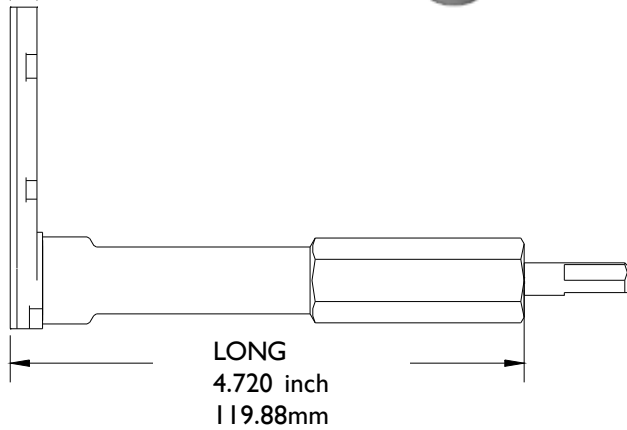
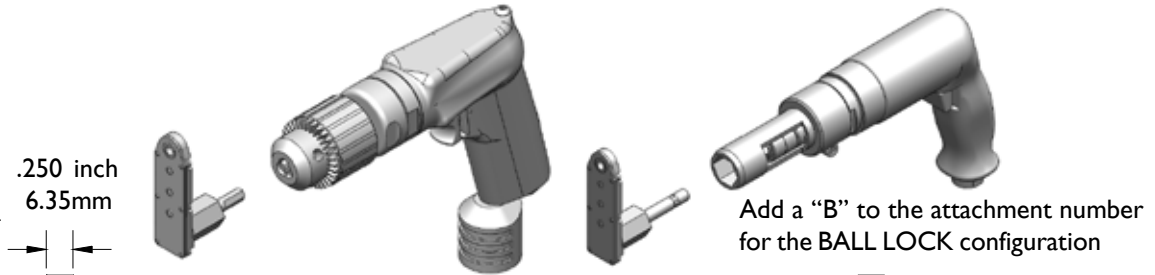

You must select an internal thread

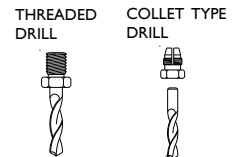

INTERNAL THREAD CODE	
1/4-28	A
10-32	C
9/32-40	E
5/16-24	F
7mm COLLET	D

PHONE: 775 883 1072 FAX: 775 883 4857

# FAD SERIES 2

## ALL BEARING FLAT ANGLE DRILLS

FOR .250 or 7 mm CHUCKS  
AND BALL LOCK ADAPTERS

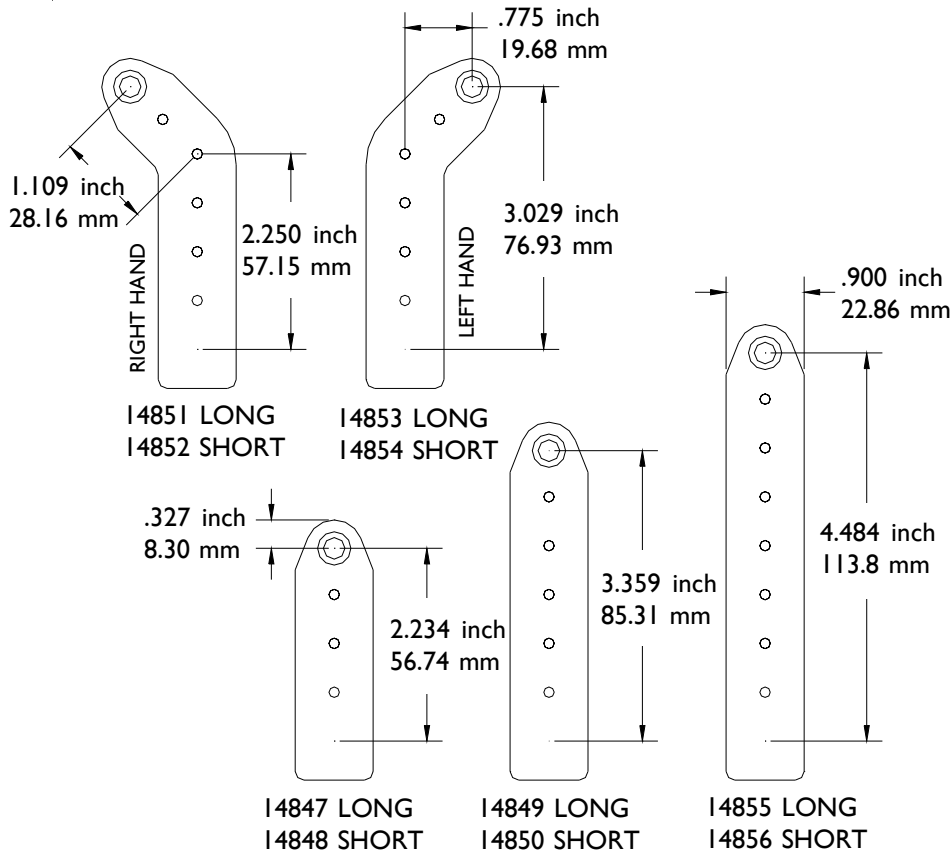
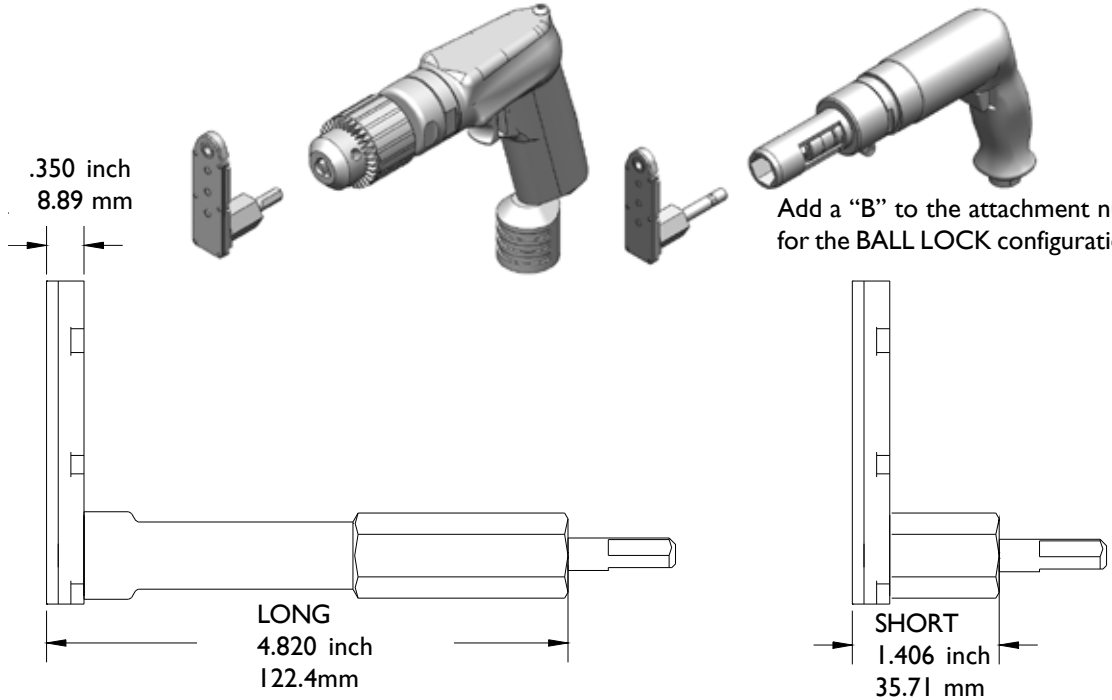

You must select an internal thread

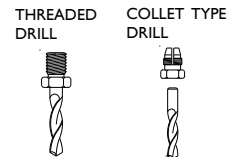

INTERNAL THREAD CODE	
1/4-28	A
10-32	C
9/32-40	E
5/16-24	F
7mm COLLET	D

PHONE: 775 883 1072 FAX: 775 883 4857

# FAD SERIES 3

## ALL BEARING FLAT ANGLE DRILLS



FOR .250 or 7 mm CHUCKS  
AND BALL LOCK ADAPTERS

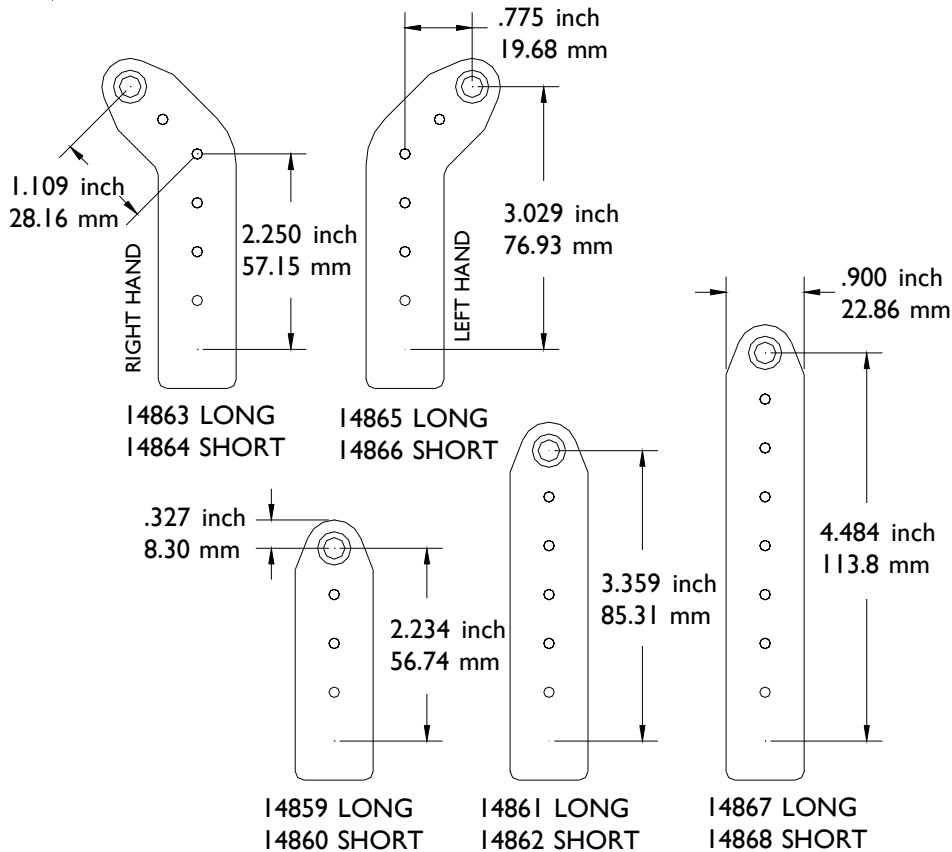
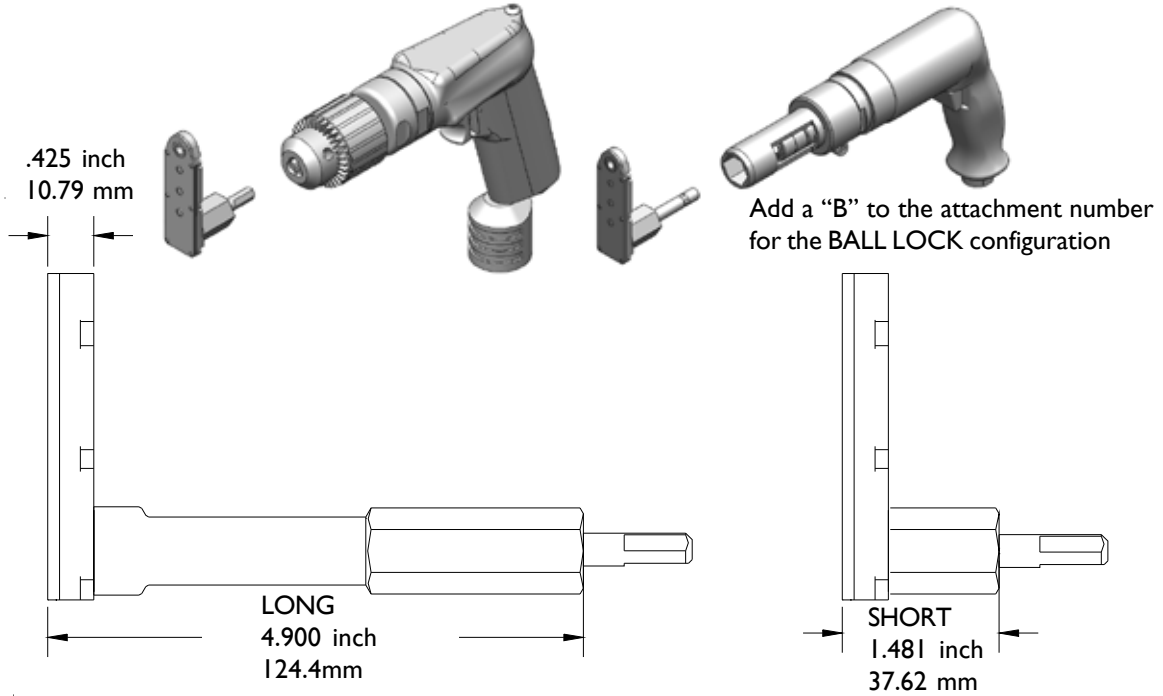

You must select an  
internal thread

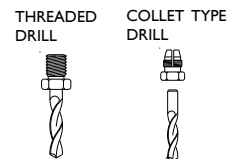

INTERNAL THREAD CODE	
1/4-28	A
10-32	C
9/32-40	E
5/16-24	F
7mm COLLET	D

PHONE: 775 883 1072 FAX: 775 883 4857

# JIFFY AIR TOOL 1.5 H.P. OFFSET MOTOR COMPLETE FOR CHUCKS



RPM	ORDER NUMBER	WEIGHT												
250	20423	3.68 LB / 1.67 KG												
<table border="1" style="width: 100%; border-collapse: collapse;"> <thead> <tr> <th colspan="3">CHUCKS</th> </tr> </thead> <tbody> <tr> <td style="text-align: center;">1/4"</td> <td style="text-align: center;">6.35mm</td> <td style="text-align: center;">17879</td> </tr> <tr> <td style="text-align: center;">3/8"</td> <td style="text-align: center;">9.52mm</td> <td style="text-align: center;">17876</td> </tr> <tr> <td style="text-align: center;">1/2"</td> <td style="text-align: center;">12.7mm</td> <td style="text-align: center;">17890</td> </tr> </tbody> </table> <p>20466 TORQUE REACTION SAFETY HANDLE REQUIRED</p>	CHUCKS			1/4"	6.35mm	17879	3/8"	9.52mm	17876	1/2"	12.7mm	17890		
CHUCKS														
1/4"	6.35mm	17879												
3/8"	9.52mm	17876												
1/2"	12.7mm	17890												
500	20993	3.15 LB / 1.43 KG												
<table border="1" style="width: 100%; border-collapse: collapse;"> <thead> <tr> <th colspan="3">CHUCKS</th> </tr> </thead> <tbody> <tr> <td style="text-align: center;">1/4"</td> <td style="text-align: center;">6.35mm</td> <td style="text-align: center;">17879</td> </tr> <tr> <td style="text-align: center;">3/8"</td> <td style="text-align: center;">9.52mm</td> <td style="text-align: center;">17876</td> </tr> <tr> <td style="text-align: center;">1/2"</td> <td style="text-align: center;">12.7mm</td> <td style="text-align: center;">17890</td> </tr> </tbody> </table> <p>20466 TORQUE REACTION SAFETY HANDLE REQUIRED</p>	CHUCKS			1/4"	6.35mm	17879	3/8"	9.52mm	17876	1/2"	12.7mm	17890		
CHUCKS														
1/4"	6.35mm	17879												
3/8"	9.52mm	17876												
1/2"	12.7mm	17890												
2000	19360	2.85 LB / 1.30 KG												
<table border="1" style="width: 100%; border-collapse: collapse;"> <thead> <tr> <th colspan="3">CHUCKS</th> </tr> </thead> <tbody> <tr> <td style="text-align: center;">1/4"</td> <td style="text-align: center;">6.35mm</td> <td style="text-align: center;">17879</td> </tr> <tr> <td style="text-align: center;">3/8"</td> <td style="text-align: center;">9.52mm</td> <td style="text-align: center;">17876</td> </tr> <tr> <td style="text-align: center;">1/2"</td> <td style="text-align: center;">12.7mm</td> <td style="text-align: center;">17890</td> </tr> </tbody> </table> <p>17908 TORQUE REACTION SAFETY HANDLE AVAILABLE</p>	CHUCKS			1/4"	6.35mm	17879	3/8"	9.52mm	17876	1/2"	12.7mm	17890		
CHUCKS														
1/4"	6.35mm	17879												
3/8"	9.52mm	17876												
1/2"	12.7mm	17890												
10,000	20380	2.95 LB / 1.30 KG												
<table border="1" style="width: 100%; border-collapse: collapse;"> <thead> <tr> <th colspan="3">CHUCKS</th> </tr> </thead> <tbody> <tr> <td style="text-align: center;">1/4"</td> <td style="text-align: center;">6.35mm</td> <td style="text-align: center;">17879</td> </tr> <tr> <td style="text-align: center;">3/8"</td> <td style="text-align: center;">9.52mm</td> <td style="text-align: center;">17876</td> </tr> <tr> <td style="text-align: center;">1/2"</td> <td style="text-align: center;">12.7mm</td> <td style="text-align: center;">17890</td> </tr> </tbody> </table> <p>17908 TORQUE REACTION SAFETY HANDLE AVAILABLE</p>	CHUCKS			1/4"	6.35mm	17879	3/8"	9.52mm	17876	1/2"	12.7mm	17890		
CHUCKS														
1/4"	6.35mm	17879												
3/8"	9.52mm	17876												
1/2"	12.7mm	17890												
3000	17551	2.26 LB / 1.03 KG												
6000	17463	2.26 LB / 1.03 KG												
20,000	17550	2.26 LB / 1.03 KG												
<table border="1" style="width: 100%; border-collapse: collapse;"> <thead> <tr> <th colspan="3">CHUCKS</th> </tr> </thead> <tbody> <tr> <td style="text-align: center;">1/4"</td> <td style="text-align: center;">6.35mm</td> <td style="text-align: center;">17879</td> </tr> <tr> <td style="text-align: center;">3/8"</td> <td style="text-align: center;">9.52mm</td> <td style="text-align: center;">17876</td> </tr> <tr> <td style="text-align: center;">1/2"</td> <td style="text-align: center;">12.7mm</td> <td style="text-align: center;">17890</td> </tr> </tbody> </table> <p>17908 TORQUE REACTION SAFETY HANDLE AVAILABLE</p>	CHUCKS			1/4"	6.35mm	17879	3/8"	9.52mm	17876	1/2"	12.7mm	17890		
CHUCKS														
1/4"	6.35mm	17879												
3/8"	9.52mm	17876												
1/2"	12.7mm	17890												

PHONE: | 775 883 1072 FAX: | 775 883 4857

# JIFFY AIR TOOL

## .9 H.P. REVERSIBLE MOTOR COMPLETE OFFSET HANDLE - FOR CHUCKS



RPM	ORDER NUMBER	WEIGHT												
250	21543	3.2 LB / 1.45 KG												
<div style="display: flex; justify-content: space-between; align-items: flex-start;"> <div style="width: 25%;"> <table border="1" style="width: 100%; border-collapse: collapse;"> <thead> <tr> <th colspan="3">CHUCKS</th> </tr> </thead> <tbody> <tr> <td style="text-align: center;">1/4"</td> <td style="text-align: center;">6.35 MM</td> <td style="text-align: center;">17879</td> </tr> <tr> <td style="text-align: center;">3/8"</td> <td style="text-align: center;">9.52 MM</td> <td style="text-align: center;">17876</td> </tr> <tr> <td style="text-align: center;">1/2"</td> <td style="text-align: center;">12.7 MM</td> <td style="text-align: center;">17890</td> </tr> </tbody> </table> </div> <div style="width: 50%; text-align: center;"> </div> </div>			CHUCKS			1/4"	6.35 MM	17879	3/8"	9.52 MM	17876	1/2"	12.7 MM	17890
CHUCKS														
1/4"	6.35 MM	17879												
3/8"	9.52 MM	17876												
1/2"	12.7 MM	17890												
500	19953	2.9 LB / 1.32 KG												
<div style="display: flex; justify-content: space-between; align-items: flex-start;"> <div style="width: 25%;"> <table border="1" style="width: 100%; border-collapse: collapse;"> <thead> <tr> <th colspan="3">CHUCKS</th> </tr> </thead> <tbody> <tr> <td style="text-align: center;">1/4"</td> <td style="text-align: center;">6.35 MM</td> <td style="text-align: center;">17879</td> </tr> <tr> <td style="text-align: center;">3/8"</td> <td style="text-align: center;">9.52 MM</td> <td style="text-align: center;">17876</td> </tr> <tr> <td style="text-align: center;">1/2"</td> <td style="text-align: center;">12.7 MM</td> <td style="text-align: center;">17890</td> </tr> </tbody> </table> </div> <div style="width: 50%; text-align: center;"> </div> </div>			CHUCKS			1/4"	6.35 MM	17879	3/8"	9.52 MM	17876	1/2"	12.7 MM	17890
CHUCKS														
1/4"	6.35 MM	17879												
3/8"	9.52 MM	17876												
1/2"	12.7 MM	17890												
1000	19954	2.7 LB / 1.22 KG												
<div style="display: flex; justify-content: space-between; align-items: flex-start;"> <div style="width: 25%;"> <table border="1" style="width: 100%; border-collapse: collapse;"> <thead> <tr> <th colspan="3">CHUCKS</th> </tr> </thead> <tbody> <tr> <td style="text-align: center;">1/4"</td> <td style="text-align: center;">6.35 MM</td> <td style="text-align: center;">17879</td> </tr> <tr> <td style="text-align: center;">3/8"</td> <td style="text-align: center;">9.52 MM</td> <td style="text-align: center;">17876</td> </tr> <tr> <td style="text-align: center;">1/2"</td> <td style="text-align: center;">12.7 MM</td> <td style="text-align: center;">17890</td> </tr> </tbody> </table> </div> <div style="width: 50%; text-align: center;"> </div> </div>			CHUCKS			1/4"	6.35 MM	17879	3/8"	9.52 MM	17876	1/2"	12.7 MM	17890
CHUCKS														
1/4"	6.35 MM	17879												
3/8"	9.52 MM	17876												
1/2"	12.7 MM	17890												
3000	19956	2.4 LB / 1.1 KG												
5000	19957	2.4 LB / 1.1 KG												
<div style="display: flex; justify-content: space-between; align-items: flex-start;"> <div style="width: 25%;"> <table border="1" style="width: 100%; border-collapse: collapse;"> <thead> <tr> <th colspan="3">CHUCKS</th> </tr> </thead> <tbody> <tr> <td style="text-align: center;">1/4"</td> <td style="text-align: center;">6.35 MM</td> <td style="text-align: center;">17879</td> </tr> <tr> <td style="text-align: center;">3/8"</td> <td style="text-align: center;">9.52 MM</td> <td style="text-align: center;">17876</td> </tr> <tr> <td style="text-align: center;">1/2"</td> <td style="text-align: center;">12.7 MM</td> <td style="text-align: center;">17890</td> </tr> </tbody> </table> </div> <div style="width: 50%; text-align: center;"> </div> </div>			CHUCKS			1/4"	6.35 MM	17879	3/8"	9.52 MM	17876	1/2"	12.7 MM	17890
CHUCKS														
1/4"	6.35 MM	17879												
3/8"	9.52 MM	17876												
1/2"	12.7 MM	17890												

PHONE: | 775 883 1072 FAX: | 775 883 4857

# JIFFY AIR TOOL .85 H.P. OFFSET MOTOR COMPLETE FOR CHUCKS



RPM	ORDER NUMBER	WEIGHT												
250	18435	1.94 LB / .88 KG												
<div style="display: flex; justify-content: space-between; align-items: flex-start;"> <table border="1" style="margin-right: 20px;"> <thead> <tr><th colspan="3">CHUCKS</th></tr> </thead> <tbody> <tr><td>1/4"</td><td>6.35mm</td><td>17879</td></tr> <tr><td>3/8"</td><td>9.52mm</td><td>17876</td></tr> <tr><td>1/2"</td><td>12.7mm</td><td>17890</td></tr> </tbody> </table> <div style="text-align: center;"> <p>3/8-24 THREAD</p> <p>6.48 IN / 164.6 MM</p> <p>5.40 IN 137 MM</p> <p>Ø 1.66 Ø 42 MM</p> </div> </div>			CHUCKS			1/4"	6.35mm	17879	3/8"	9.52mm	17876	1/2"	12.7mm	17890
CHUCKS														
1/4"	6.35mm	17879												
3/8"	9.52mm	17876												
1/2"	12.7mm	17890												
500	17839	1.75 LB / .79 KG												
500	17874 "TOOLING TECHNOLOGY THREAD"	1.75 LB / .79 KG												
<div style="display: flex; justify-content: space-between; align-items: flex-start;"> <table border="1" style="margin-right: 20px;"> <thead> <tr><th colspan="3">CHUCKS</th></tr> </thead> <tbody> <tr><td>1/4"</td><td>6.35mm</td><td>17879</td></tr> <tr><td>3/8"</td><td>9.52mm</td><td>17876</td></tr> <tr><td>1/2"</td><td>12.7mm</td><td>17890</td></tr> </tbody> </table> <div style="text-align: center;"> <p>3/8-24 THREAD</p> <p>5.42 IN / 137.6 MM</p> <p>5.40 IN 137 MM</p> <p>Ø 1.66 Ø 42 MM</p> </div> </div>			CHUCKS			1/4"	6.35mm	17879	3/8"	9.52mm	17876	1/2"	12.7mm	17890
CHUCKS														
1/4"	6.35mm	17879												
3/8"	9.52mm	17876												
1/2"	12.7mm	17890												
1000	17850	1.60 LB / .73 KG												
<div style="display: flex; justify-content: space-between; align-items: flex-start;"> <table border="1" style="margin-right: 20px;"> <thead> <tr><th colspan="3">CHUCKS</th></tr> </thead> <tbody> <tr><td>1/4"</td><td>6.35mm</td><td>17879</td></tr> <tr><td>3/8"</td><td>9.52mm</td><td>17876</td></tr> <tr><td>1/2"</td><td>12.7mm</td><td>17890</td></tr> </tbody> </table> <div style="text-align: center;"> <p>3/8-24 THREAD</p> <p>5.17 IN / 131.3 MM</p> <p>5.40 IN 137 MM</p> <p>Ø 1.50 Ø 38 MM</p> </div> </div>			CHUCKS			1/4"	6.35mm	17879	3/8"	9.52mm	17876	1/2"	12.7mm	17890
CHUCKS														
1/4"	6.35mm	17879												
3/8"	9.52mm	17876												
1/2"	12.7mm	17890												
2000	17851	1.60 LB / .73 KG												
<div style="display: flex; justify-content: space-between; align-items: flex-start;"> <table border="1" style="margin-right: 20px;"> <thead> <tr><th colspan="3">CHUCKS</th></tr> </thead> <tbody> <tr><td>1/4"</td><td>6.35mm</td><td>17879</td></tr> <tr><td>3/8"</td><td>9.52mm</td><td>17876</td></tr> <tr><td>1/2"</td><td>12.7mm</td><td>17890</td></tr> </tbody> </table> <div style="text-align: center;"> <p>3/8-24 THREAD</p> <p>5.82 IN / 147.8 MM</p> <p>5.40 IN 137 MM</p> <p>Ø 1.60 Ø 40.6 MM</p> </div> </div>			CHUCKS			1/4"	6.35mm	17879	3/8"	9.52mm	17876	1/2"	12.7mm	17890
CHUCKS														
1/4"	6.35mm	17879												
3/8"	9.52mm	17876												
1/2"	12.7mm	17890												
3000	17832	1.50 LB / .68 KG												
6000	17852	1.50 LB / .68 KG												
<div style="display: flex; justify-content: space-between; align-items: flex-start;"> <table border="1" style="margin-right: 20px;"> <thead> <tr><th colspan="3">CHUCKS</th></tr> </thead> <tbody> <tr><td>1/4"</td><td>6.35mm</td><td>17879</td></tr> <tr><td>3/8"</td><td>9.52mm</td><td>17876</td></tr> <tr><td>1/2"</td><td>12.7mm</td><td>17890</td></tr> </tbody> </table> <div style="text-align: center;"> <p>3/8-24 THREAD</p> <p>4.55 IN / 115.6 MM</p> <p>5.40 IN 137 MM</p> <p>Ø 1.50 Ø 38 MM</p> </div> </div>			CHUCKS			1/4"	6.35mm	17879	3/8"	9.52mm	17876	1/2"	12.7mm	17890
CHUCKS														
1/4"	6.35mm	17879												
3/8"	9.52mm	17876												
1/2"	12.7mm	17890												

PHONE: 1 775 883 1072 FAX: 1 775 883 4857

**JIFFY AIR TOOL**  
**.3 H.P. OFFSET MOTOR COMPLETE**  
**FOR CHUCKS**  
**- DOWN EXHAUST -**



RPM	ORDER NUMBER	WEIGHT
250	22799	1.6 LB / .72 KG
500	22800	1.6 LB / .72 KG
750	22801	1.6 LB / .72 KG
1000	22802	1.6 LB / .72 KG
1500	22803	1.6 LB / .72 KG

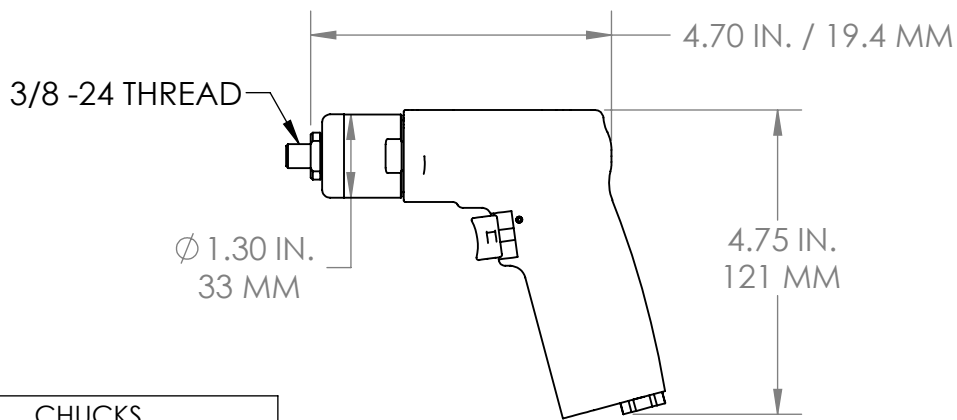

CHUCKS		
1/4 "	6.35 MM	17879
3/8 "	9.52 MM	17876

2800	22804	1.2 LB / .55 KG
4500	22805	1.2 LB / .55 KG

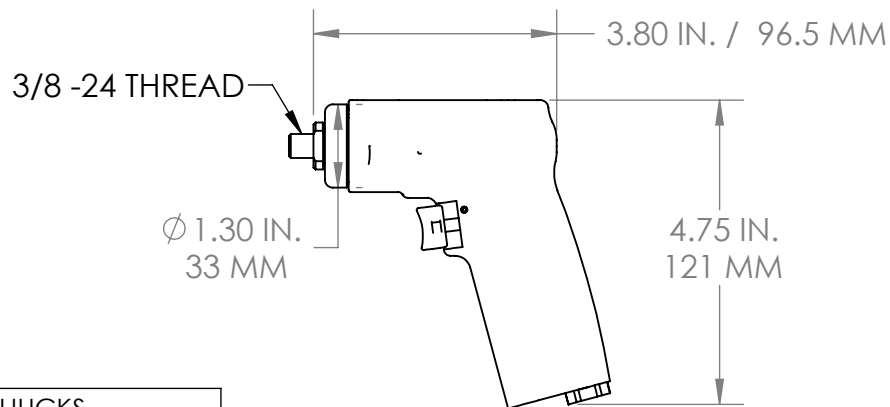

CHUCKS		
1/4 "	6.35 MM	17879
3/8 "	9.52 MM	17876

PHONE: 1 775 883 1072 FAX: 1 775 883 4857

# JIFFY TORQUE REACTION SAFETY HANDLES

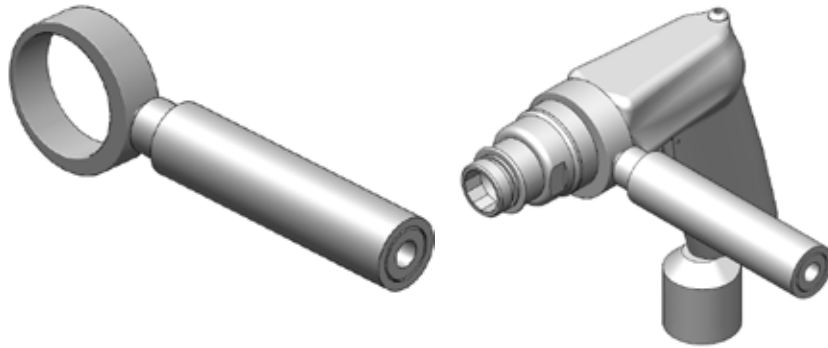

17908 TORQUE REACTION HANDLE SMALL	
MOTOR HP	RPM
1.5	2000
	3000
	6000
	10,000
	20,000
.90 REVERSIBLE	1000
	3000
	5000
.85	250
	500
	1000
	2000
	3000
	6000

20466 TORQUE REACTION HANDLE LARGE	
MOTOR HP	RPM
1.5	250
	500
.90	250
	500

PHONE: | 775 883 1072 FAX: | 775 883 4857



## 18108 SUPER DUTY 90 DEGREE HEAD



FULL BEARING  
ATTACHMENT  
UP TO 6000 RPM

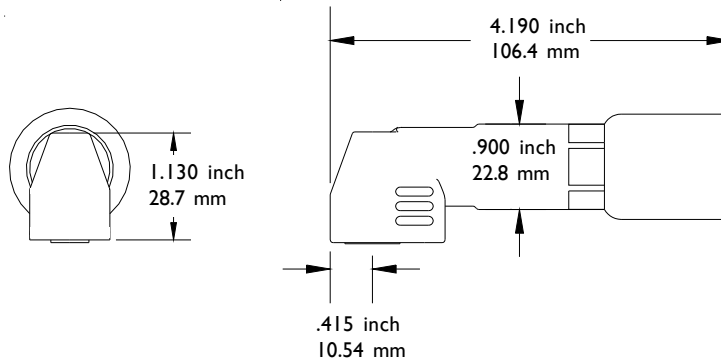

INTERNAL THREAD CODE	
1/4-28	A
9/32-40	E
5/16-24	F
3/8-24 FEMALE	Z
7mm COLLET	D
3/8-24 MALE	Y

## 14177 90 DEGREE STANDARD DUTY DRILL HEAD

FULL BEARING  
ATTACHMENT  
UP TO 6000 RPM

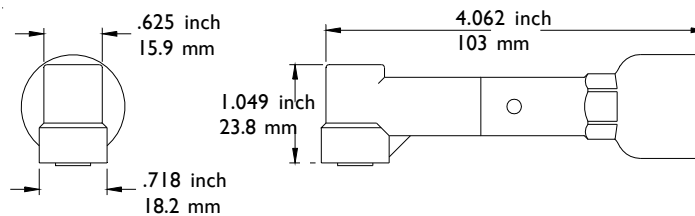

INTERNAL THREAD CODE	
1/4-28	A
10-32	C
9/32-40	E
7mm COLLET	D

## 20917 90 DEGREE LOW PROFILE DRILL HEAD

FULL BEARING  
ATTACHMENT  
UP TO 6000 RPM

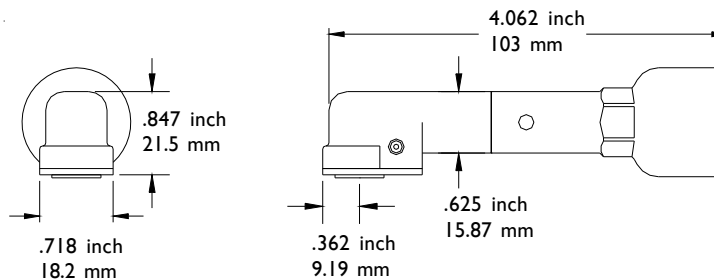

INTERNAL THREAD CODE	
1/4-28	A
10-32	C
9/32-40	E
7mm COLLET	D

## 17900 CLOSE CENTER TO EDGE DRILL HEAD

BUSHING TYPE  
ATTACHMENT  
3000 RPM MAXIMUM

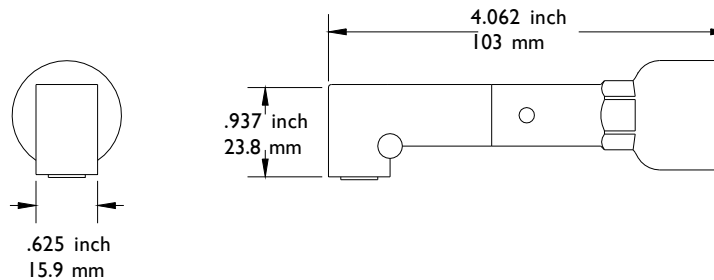

INTERNAL THREAD CODE	
1/4-28	A
10-32	C
9/32-40	E
5/16-24	F
7mm COLLET	D

One inch 20 pitch thread with  
nine tooth spline drive adapts to  
Dotco  
American Pneumatic  
Buckeye  
Rockwell  
DeSoutter

## 17688 45 DEGREE SUPER DUTY DRILL HEAD



FULL BEARING  
ATTACHMENT  
UP TO 6000 RPM

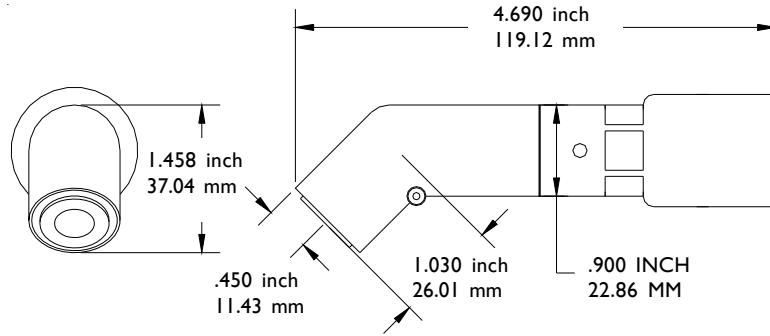

INTERNAL THREAD CODE	
1/4-28	A
9/32-40	E
5/16-24	F
3/8-24 FEMALE	Z
7mm COLLET	D
3/8-24 MALE	Y

## 17901 45 DEGREE CLOSE CENTER TO EDGE DRILL HEAD

BUSHING TYPE  
ATTACHMENT  
3000 RPM MAXIMUM

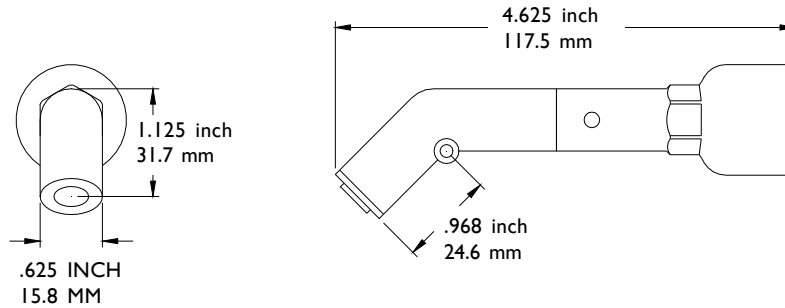

INTERNAL THREAD CODE	
1/4-28	A
10-32	C
9/32-40	E
5/16-24	F
7mm COLLET	D

## 17725 360 DEGREE STANDARD DUTY DRILL HEAD

FULL BEARING  
ATTACHMENT  
UP TO 6000 RPM

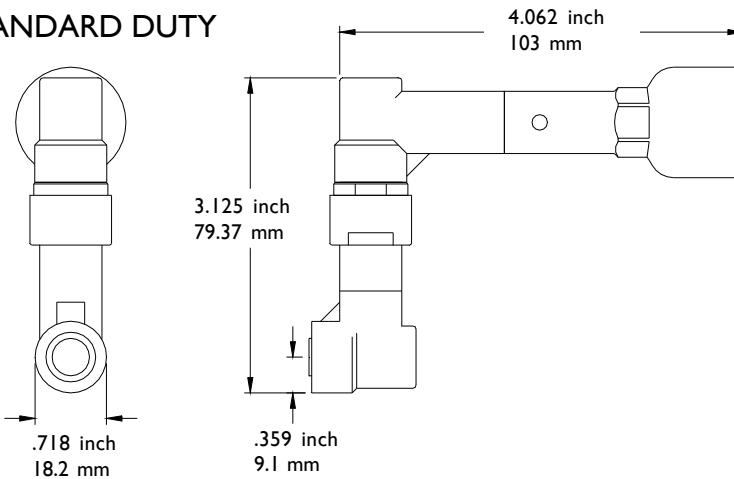

INTERNAL THREAD CODE	
1/4-28	A
10-32	C
9/32-40	E
7mm COLLET	D

## 20918 360 DEGREE CLOSE CENTER TO EDGE DRILL HEAD

BUSHING TYPE  
ATTACHMENT  
3000 RPM MAXIMUM

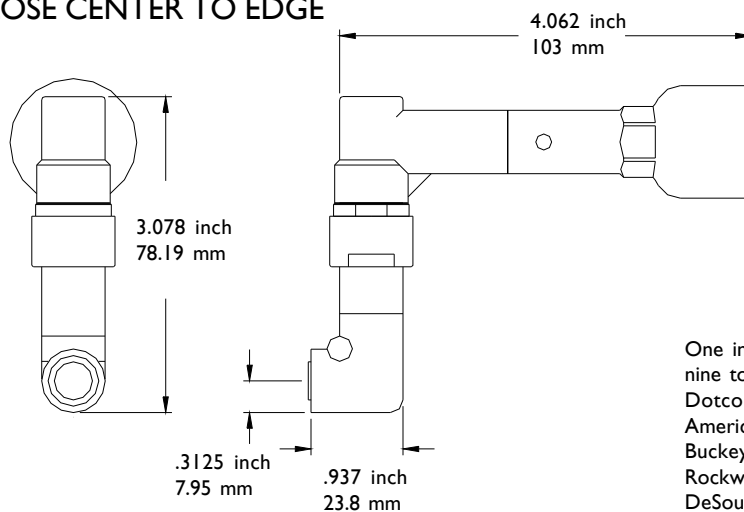

INTERNAL THREAD CODE	
1/4-28	A
10-32	C
9/32-40	E
5/16-24	F
7mm COLLET	D

One inch 20 pitch thread with  
nine tooth spline drive adapts to  
Dotco  
American Pneumatic  
Buckeye  
Rockwell  
DeSoutter



## 20910 SERIES | PANCAKE DRILL

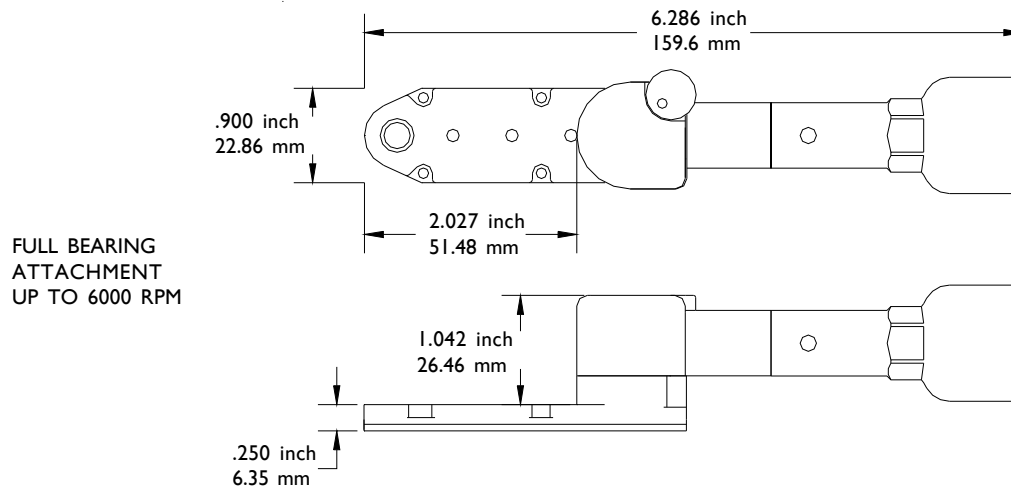

You must select an internal thread

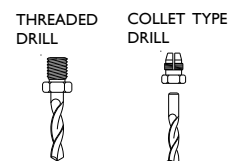

INTERNAL THREAD CODE	
1/4-28	A
10-32	C
9/32-40	E
5/16-24	F
7mm COLLET	D

## 20911 SERIES | PANCAKE DRILL

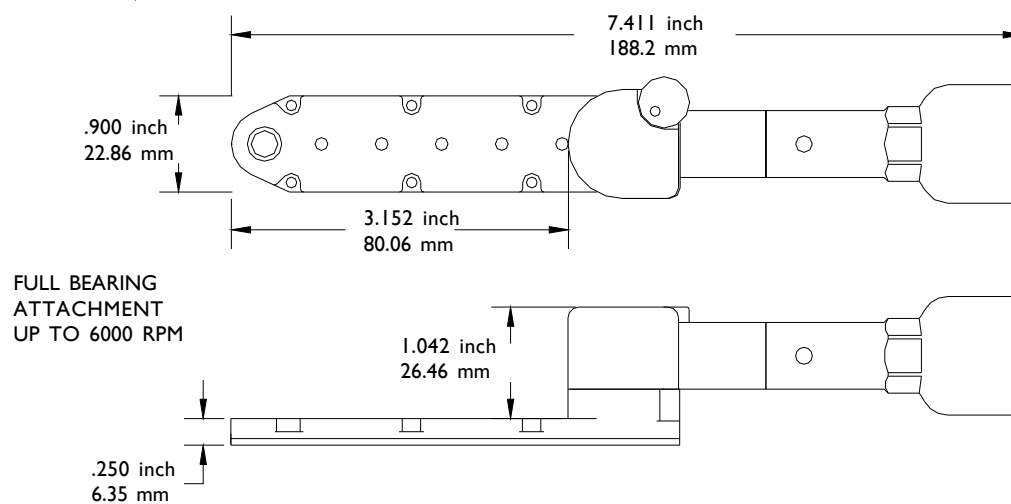

One inch 20 pitch thread with nine tooth spline drive adapts to  
 Dotco  
 American Pneumatic  
 Buckeye  
 Rockwell  
 DeSoutter

### 20912 SERIES 2 PANCAKE DRILL

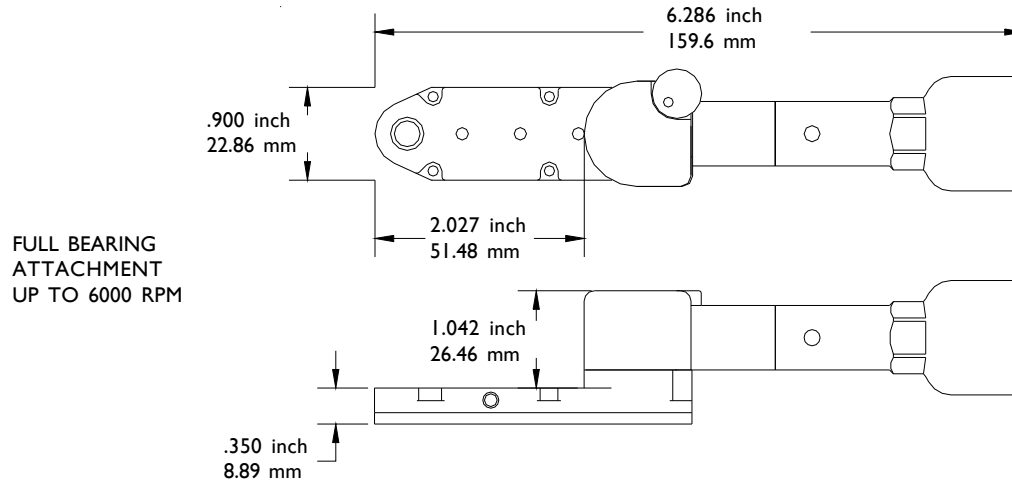

FULL BEARING  
ATTACHMENT  
UP TO 6000 RPM

You must select an  
internal thread

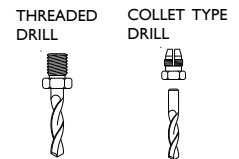

INTERNAL THREAD CODE	
1/4-28	A
10-32	C
9/32-40	E
5/16-24	F
7mm COLLET	D

### 20913 SERIES 2 PANCAKE DRILL

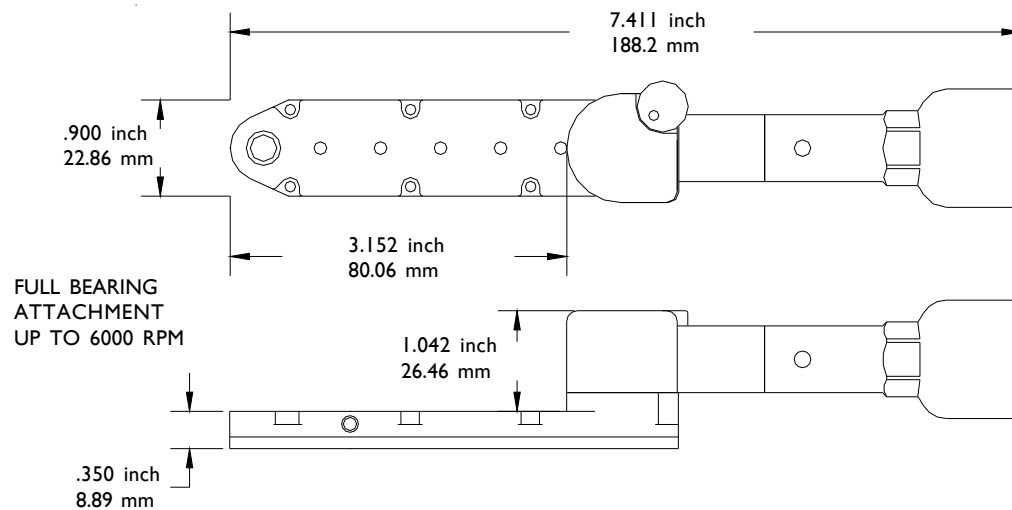

FULL BEARING  
ATTACHMENT  
UP TO 6000 RPM

One inch 20 pitch thread with  
nine tooth spline drive adapts to  
Dotco  
American Pneumatic  
Buckeye  
Rockwell  
DeSoutter

## 20914 SERIES 4 PANCAKE DRILL

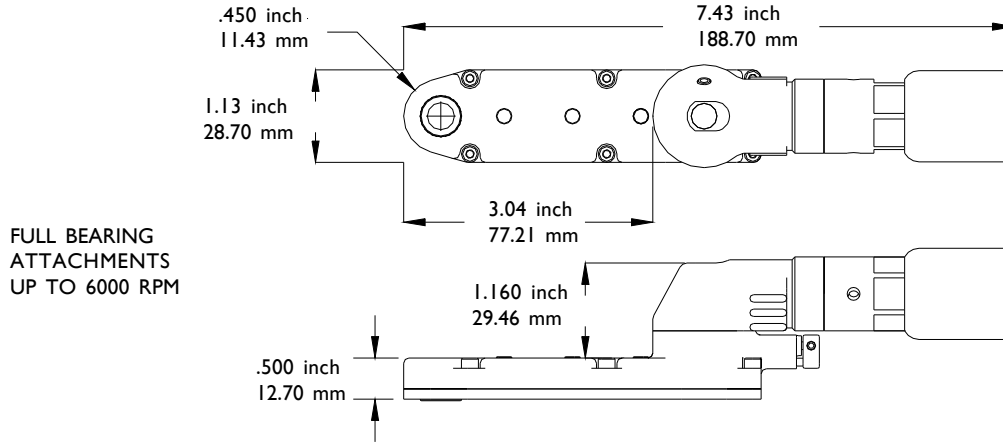

## 20915 SERIES 4 PANCAKE DRILL

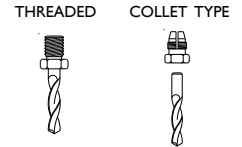
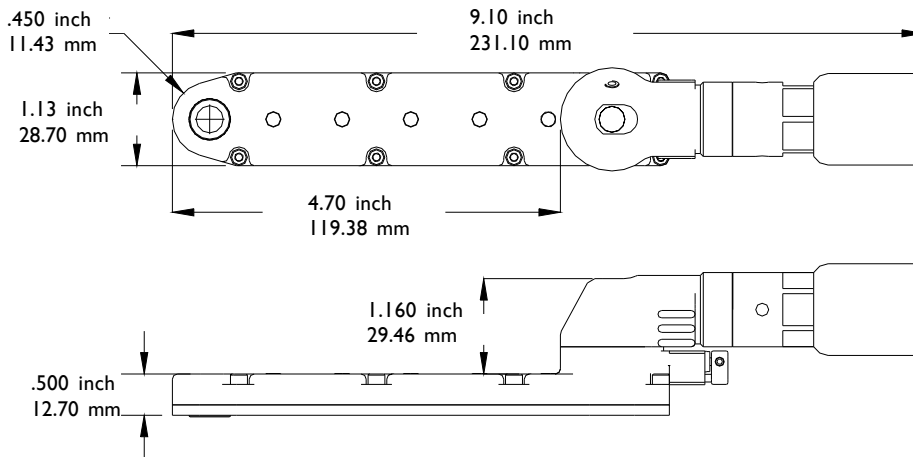

INTERNAL THREAD CODE	
1/4-28	A
9/32-40	E
5/16-24	F
3/8-24	Z
7mm COLLET	D
3/8-24 MALE	Y

## 20916 SERIES 4 PANCAKE DRILL

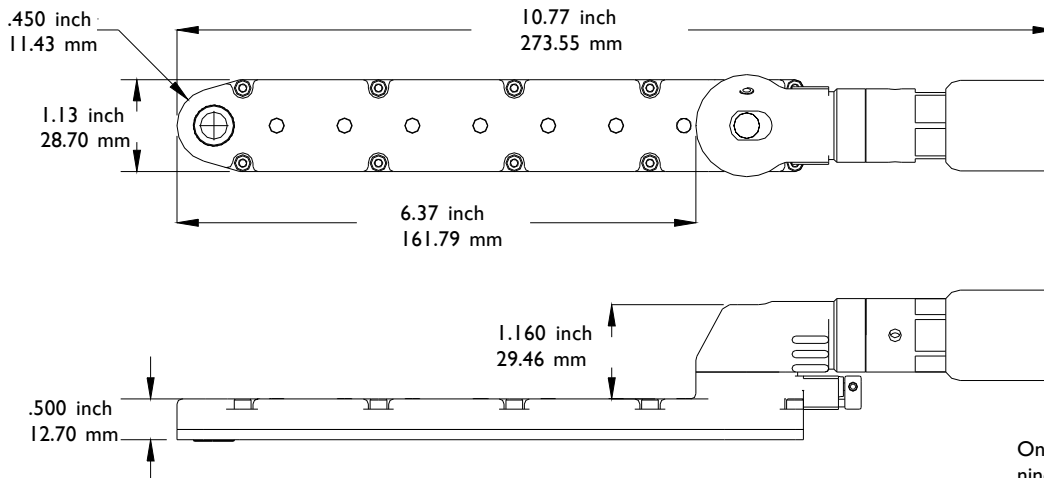

One inch 20 pitch thread with nine tooth spline drive adapts to  
 Dotco  
 American Pneumatic  
 Buckeye  
 Rockwell  
 DeSoutter



## LUBRICATION INSTRUCTIONS

### AIR SUPPLY

Our tools are designed to operate at 90 pounds per square inch air pressure. The pressure should be checked at the tools inlet with the tool running. For maximum performance use a 1/4" inside diameter air hose up to 8 foot in length. If additional length is required a 3/8" or larger inside diameter should be connected to the 1/4" inside diameter hose. All hoses should be clear of dirt and moisture.

### AIR LINE LUBRICATION

An automatic in-line filter-lubricator is recommended as it increases tool life and provides needed lubrication for tools in sustained operation. The in-line lubricator should be regularly checked and filled Catoil from Industrial Lubricants [www.catoil.biz](http://www.catoil.biz). Proper adjustment of the in-line lubricator is performed by placing a sheet of paper next to the exhaust ports of the tool and holding the throttle open for approximately one minute. The lubricator is set correctly when a very light stain of oil collects on the paper. Excessive amounts of oil should be avoided. In the event that it becomes necessary to store the tool for an extended amount of time it should receive a generous amount of lubrication at that time and again when returned to service. The tool should be stored in a clean and dry environment. Care should be taken to absorb any excess oil from the exhaust with a suitable cloth or rag when the tool is first run with air after storage.

### GEAR TRAIN LUBRICATION

Application of the tool should govern how frequently it is greased. It is recommended that the gear cases receive several squirts Magnalube-G from Saunders Enterprises [www.magnalube.com](http://www.magnalube.com) after forty hours of operation.

### ATTACHMENT LUBRICATION

The attachments should be greased once a day if used in sustained operation. Failure to lubricate attachments will cause premature wear and short attachment life. The grease gun used should fit a alemite #1877 fitting. We recommend Magnalube-G grease [www.magnalube.com](http://www.magnalube.com) for best performance.



**RECOMMENDED DRILL RPM'S PER DRILL SIZE**

MATERIAL	#40	1/8	5/32	3/16	7/32	1/4	9/32	5/16	11/32	3/8	13/32	7/16	15/32	1/2
ALUMINIUM	5500	5000	4000	3500	3000	2700	2600	2000	2000	1800	1800	1800	1500	1500
INCONEL	500	300	300	300	250	250	250	150	150	150	150	150	100	100
17-7	900	650	650	500	450	300	300	300	250	250	250	250	150	150
STAINLESS STEEL	1100	750	750	650	500	450	300	300	300	300	300	250	250	250
TITANIUM	750	500	500	450	300	300	250	250	250	150	150	150	150	150
HASTELLOY	500	300	300	300	250	250	250	150	150	150	150	150	100	100
PLAIN STEEL	2000	1500	1400	1200	1000	900	900	750	650	650	500	500	500	450



# FRACTION-DECIMAL-MILLIMETER CONVERSION CHART

INCHES		MM	INCHES		MM
	$\frac{1}{64}$	.015625	.3969		
$\frac{1}{32}$		.03125	.7938	$\frac{17}{32}$	.515625
	$\frac{3}{64}$	.046875	1.1906		$\frac{35}{64}$
$\frac{1}{16}$		.0625	1.5875	$\frac{9}{16}$	.5625
	$\frac{5}{64}$	.078125	1.9844		$\frac{37}{64}$
$\frac{3}{32}$		.09375	2.3813	$\frac{19}{32}$	.59375
	$\frac{7}{64}$	.109375	2.7781		$\frac{39}{64}$
$\frac{1}{8}$		.125	3.1750	$\frac{5}{8}$	.625
	$\frac{9}{64}$	.140625	3.5719		$\frac{41}{64}$
$\frac{5}{32}$		.15625	3.9688	$\frac{21}{32}$	.65625
	$\frac{11}{64}$	.171875	4.3656		$\frac{43}{64}$
$\frac{3}{16}$		.1875	4.7625	$\frac{11}{16}$	.6875
	$\frac{13}{64}$	.203125	5.1594		$\frac{45}{64}$
$\frac{7}{32}$		.21875	5.5563	$\frac{23}{32}$	.71875
	$\frac{15}{64}$	.234375	5.9531		$\frac{47}{64}$
$\frac{1}{4}$		.250	6.3500	$\frac{3}{4}$	.750
	$\frac{17}{64}$	.265625	6.7469		$\frac{49}{64}$
$\frac{9}{32}$		.28125	7.1438	$\frac{25}{32}$	.78125
	$\frac{19}{64}$	.296875	7.5406		$\frac{51}{64}$
$\frac{5}{16}$		.3125	7.9375	$\frac{13}{16}$	.8125
	$\frac{21}{64}$	.328125	8.3344		$\frac{53}{64}$
$\frac{11}{32}$		.34375	8.7313	$\frac{27}{32}$	.84375
	$\frac{23}{64}$	.359375	9.1282		$\frac{55}{64}$
$\frac{3}{8}$		.375	9.5250	$\frac{7}{8}$	.875
	$\frac{25}{64}$	.390625	9.9219		$\frac{57}{64}$
$\frac{13}{32}$		.40625	10.3188	$\frac{29}{32}$	.90625
	$\frac{27}{64}$	.421875	10.7157		$\frac{59}{64}$
$\frac{7}{16}$		.4375	11.1125	$\frac{15}{16}$	.9375
	$\frac{29}{64}$	.453125	11.5094		$\frac{61}{64}$
$\frac{15}{32}$		.46875	11.9063	$\frac{31}{32}$	.96875
	$\frac{31}{64}$	.484375	12.3032		$\frac{63}{64}$
$\frac{1}{2}$		.500	12.7001	$\frac{1}{1}$	1.000